

Tips, products and solutions for efficient load safety



Good to know you're
backed by Sortimo

Sortimo®

The moment of truth
can sometimes appear
very unexpectedly...

Are you prepared if
the worst should happen?



Keeping it legal

Clear guidance from the legislature

Between 1995 and 2009 the number of vans on our streets increased by around 25 percent.

The number of traffic accidents in which vans were involved increased by more than 50 percent.

This demonstrates the problems of this vehicle category. Most of the vehicles are involved in trade and service.

It turns out that in the documented accidents, the load safety was often neglected and has significantly contributed to the accident situation.

Many drivers are not aware that failing to load safely, breaks regulations and laws and thus makes them liable to prosecution. This is valid for the driver, the vehicle owner and for the loading personnel. Following we've summarized the most important regulations.

§ 31 StVZO*

Responsibility for the operation of the vehicles

1. Anyone who drives a vehicle or a train of vehicles must be capable of operating the vehicle.
2. The owner shall not demand or permit the operation if he is aware or should have known that the driver isn't capable of independent driving, or if the vehicle, the train, the rig,

the cargo or the team is not as prescribed or that the traffic safety of the vehicle is compromised by the load or the work team.

§ 9 (13) GGVSE*

Duties

The loader and the driver must observe the rules of the road regarding loading and handling in accordance with Chapter 7.5 ADR.

§ 9 (12) GGVSE*

Duties

The owner and the carrier shall meet their obligations under § 9, Paragraph 12, No. 7 GGVSE to ensure that in traffic the driver has the necessary equipment available for the correct implementation of load safety.

§ 22 (1) StVO*

Load

The cargo, including the equipment for load safety as well as cargo handling equipment must be stowed and secured so that even when braking suddenly or during an evasive maneuver, they don't slip, fall over, don't roll back and forth or create avoidable noise. Recognized rules of technology have to be followed.

§ 7 (1) StVO*

Liability of the owner

If a person is killed or physically injured while operating a vehicle or a trailer designed for usage with a vehicle, or if goods are damaged, then the owner of the vehicle is liable for compensation to the injured party.

§ 23 StVO*

Other duties

The driver is responsible for not having his vision and hearing impaired by the work team, animals, cargo, equipment or the condition of the vehicle. He must ensure that the vehicle, the rig, the train and the work team comply with the rules, and that the road safety of the vehicle is not impaired by the cargo or the work team.

§ 229 StGB*

Bodily injury caused by negligence

Whoever through negligence causes personal injury to another person, will be punished with imprisonment of up to three years or fined.

* German legal position



2007: sled test with Sortimo in-vehicle equipment of the 3rd Generation in France carried out with the UTAC.

Crash tests prove it

Load safety pays off

Order and safety are two values that are closely related to each other. Because without order there is no safety. Therefore Sortimo has been carrying out crash tests for more than 30 years with our partners from the ADAC, DEKRA, TRL, TÜV and UTAC.

Only in simulated emergencies can we find out if our in-vehicle equipment really meets the highest standards in load safety.

To date we have performed superbly in all crash tests. This shows us that we are on the right track. Ultimately it is for your personal safety and your valuable cargo.

2003: side-impact crash tests for comparison between secured and unsecured cargo.



1986: sled test with Sortimo large drawer in a station wagon car

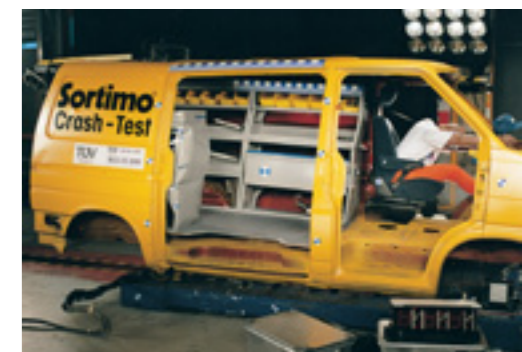

2000: sled test with Sortimo in-vehicle equipment at TÜV Munich



2004: sled test with Sortimo Globelyst in-vehicle equipment of the 3rd Generation with ADAC Bavaria



2009: ADAC crash test with Carmo floor plate and loaded and secured L-BOXXes with rear seat folded down at 50 km/h.

The order system for safe transportation.

Sortimo T-BOXX

Practical plastic case with transparent lid. Therefore the contents of the inset boxes are always visible. The T-BOXX can be safely stored in the in-vehicle equipment.

Shelves and Trays

Take advantage of every inch of space in your vehicle. Spare parts and small parts will find their place on the shelves and trays from Sortimo Globelyst.

Sortimo L-BOXXes

Variable plastic boxes in four sizes. The L-BOXXes can be clicked together and transported comfortably as a unit.

Sortimo M-BOXX

Large mobile box with handle. Optionally available with a lid. The M-BOXX snaps into the system and can be used as a drawer.

Long components tray

The transportation of long objects can be done within the vehicle. The long components tray sits on top of the in-vehicle equipment and takes advantage of the entire vehicle length.

Sortimo Accessories

Many additional products and original accessories complete the range and are a useful complement to the industry-specific in-vehicle equipment. From the cable holder to the cable hook all requirements are covered.

Sortimo S-BOXX

The drawer boxes come in two widths. They are ideal as a container for small parts, spare parts or screws and can be securely locked on the box floor and shelf.

Sortimo Case

The Sortimo legend. The sturdy metal case comes in many varieties. In the in-vehicle equipment it can be fully extended and opened on the case rails.

Drawers

The practical drawers have a lock and are stable even at full extension. With their four different widths they are perfectly integratable in the in-vehicle equipment.

Sortimo Globelyst

Sortimo in-vehicle equipment offers plenty of space for the perfect transportation and storage of small parts and cargo. The mobile product ranges such as cases and BOXXes can be safely stowed.

Case clamp

It provides for a secure grip for the tool or machine cases. The containers can be easily clamped.

Cargo bars

Sortimo offers a wide range of lashing and securing facilities. The cargo bars can be variably used in the horizontal and vertical position.

Mobile workbenches

Transform your commercial vehicle into a mobile workshop. The mobile workbenches are available as folding and extendable versions. They are all very stable and resilient.

Shutter and lift up flap

These parts of the in-vehicle equipment provide additional tidiness and safety in commercial vehicles.

Safety floors

The basis of your success. Sortimo has several safety floors and floor inserts in the range. The Sortimo Globelyst in-vehicle equipment is placed on the safety floor.



Typical loads – problems and solutions

Typical load	Problems in load safety	Solutions from Sortimo	please go to
Work clothes	Lying around untidily	Simply hang on the hooks on the in-vehicle equipment	page 105
Brooms	are bulky and can fall over	Mounting under the vehicle ceiling	page 105
Burner nozzles	are sensitive and must be stowed clearly and safely	Burner nozzle inserts in the case and the L-BOXX	page 77, 88
Buckets	shall not move back and forth in the loading area	Rack system with open shelves, lift up flaps etc.	page 42 ff
Spare parts	must be clearly arranged and be quick at hand	Basket shelves for vehicle equipment, S-, M-, T- and L-BOXX, cases	page 43, 72 ff
Gas bottles	Dangerous – safe stowage and venting required!	Gas bottle holders, ventilation in the vehicle	page 60 ff
Canisters	should be stowed so they are leak proof	Canister holders, rack systems	page 108
Cartons	must be secured to prevent movement and damage	Support sling, load security net, lashing straps, Express shelving	page 22 ff, 32
Cartridges	are often stored disorderly	L-BOXX and M-BOXX with cartridge inserts	page 89, 91
Small parts	are not allowed to mix	Inset boxes in drawers, cases, T-BOXX or L-BOXX	page 72 ff
Coolant bottles	Dangerous – safe stowage and venting required!	Coolant shelf, efficient ventilation in the vehicle	page 60 ff
Ladders	are long and bulky	Roof rack system, TopSystem or telescope ladders	page 66 ff, 111
Equipment cases	are heavy and aren't allowed to be stowed unsecured	Case clamp	page 43, 57
Measuring instruments	are valuable and must be well protected during transport	Cases, L-BOXX and M-BOXX with foam inserts	page 77, 88, 91
Mobile containers	like cases, T-BOXX, M-BOXX, or L-BOXX	Professional in-vehicle equipment Sortimo Globelyst	page 40 ff
Furniture	are heavy, bulky and should not move	Cargo bars, lashing straps, support slings	page 20 ff
Pallets	is heavy and bulky	Anti-rattle mat, pallet stoppers, load security net	page 20 ff
Tubes	are long and unwieldy	Long components trays in the vehicle or roof rack system TopSystem	page 57, 68
Hoses	tangle easily	Cable holder on the vehicle equipment	page 103
Heavy cargo	often not easy to remove from the vehicle	Loading platform	page 52
Doors and windows	are big and bulky	Sortimo Reff, cargo bars	page 22 ff
Washing machines	is unwieldy and heavy	Cargo bars, anti-rattle mat, support slings, lashing straps, pallet stoppers	page 20 ff
Tools	should be stowed safely and quickly accessible	Shelf system with drawers, cases, T-BOXX, M-BOXX or L-BOXX	page 40 ff, 72 ff

Contents by chapter:

Floor and wall covering	12
Safe and secure fastening	18
Vehicle equipment and pre-assembled units	36
Hazardous materials, ventilation	60
Roof rack and ladder-lift	66
Mobile assortments	72
Mobile office	92
Original Accessories	100
Service – Sortimo partners	118



Floor and wall covering

The first step towards the correct protection for vehicle and cargo

Sensible load safety begins with the proper cladding of the vehicle interior! Sortimo offers the right solution with different floors and wall coverings for all purposes. The Sortimo protection package provides the additional possibility to integrate lashing systems into the empty vehicle, thus taking the first steps towards safety.



Whether chestnuts, walnuts, or the shells in the ocean – nature knows how they can protect their valuable contents successfully against damage. You can too. Protect your cargo and your van against damage with the Sortimo safety packages.

The professional safety package

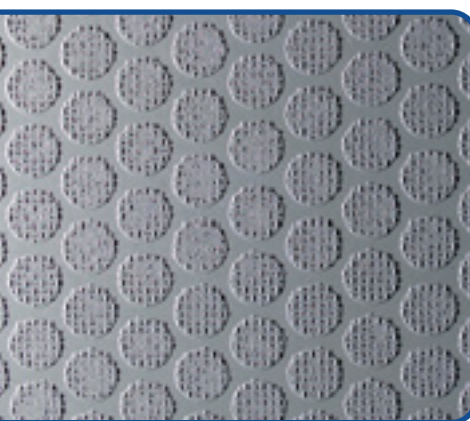
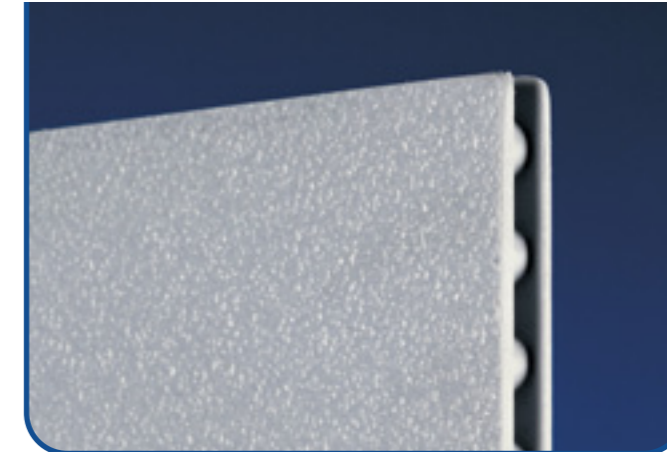
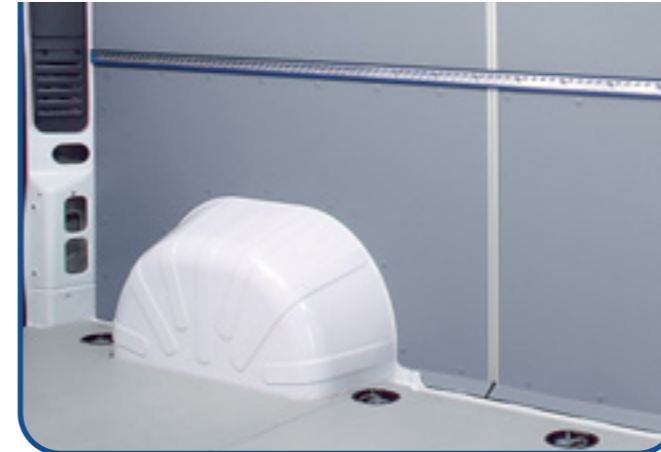

Sobogrip® - the value-added protective floor

- ▶ 9 mm thick protective floor and integrated lashing tracks
- ▶ 7-ply laminated waterproof (for BFU 100), selected Nordic birch wood
- ▶ All standard lashing eyes in vans remain freely accessible
- ▶ Cut-to-size floor for all current vehicle models
- ▶ Direction neutral knobbed high performance coating, anti-slip in all directions – even when wet or after years of usage
- ▶ Aluminum wear strips to protect the access points
- ▶ The protective floor is resistant to dirt and water, easy to clean and extremely scratch and impact resistant
- ▶ The floor plate is in several sections and therefore easy to install

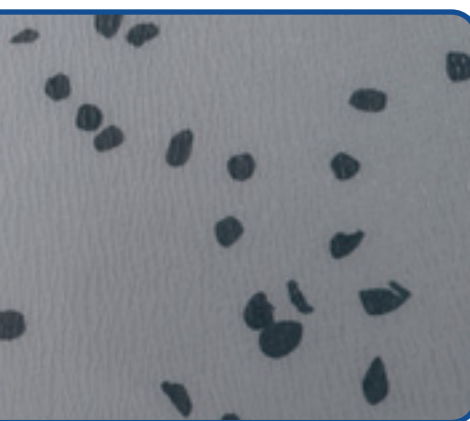

Soboflex® - Safety floor

- ▶ 13 mm safety floor, grey
- ▶ The in-vehicle equipment is bolted down to the safety floor
- ▶ No drilling of the vehicle floor – retaining better residual value – especially for leased vehicles
- ▶ Contains no endangered tropical hardwoods
- ▶ Chlorine free surface veneer
- ▶ 9-ply waterproof laminated (for BFU 100) selected Nordic birch wood
- ▶ Pre-fitted insert nut locations for additional lashing points
- ▶ Rapid installation of pre-cut shapes for all vehicle types
- ▶ Aluminium wear strips at access points
- ▶ Non-slip Soboflex®-veneer – even when wet (complies with StVZO §35 d)
- ▶ Highly resistant to wear (65 times more than normally available plywood)
- ▶ Resistant to oils, petrol and most chemicals
- ▶ Protects the load area and is easy to clean

All prices plus VAT and shipping. Our delivery and payment terms are applicable. See: www.sortimo.com/GTCT Prices are only applicable for orders within Germany.

Find the right floor plate or wall covering for your vehicle. Please call us on phone **+49 8291 850-459** or fax us **+49 8291 850-249**.

SowaPro® - the tough wall cladding

- ▶ SowaPro® provides optimum cargo space protection and thus effective body protection from the inside. The complete set includes door cladding.
- ▶ Perfect fit for all vehicle models
- ▶ The gray-coated, sturdy HDF board with 4 mm thickness is environmentally friendly and made from 100% recycled material
- ▶ The surface of SowaPro® is particularly smooth and resilient

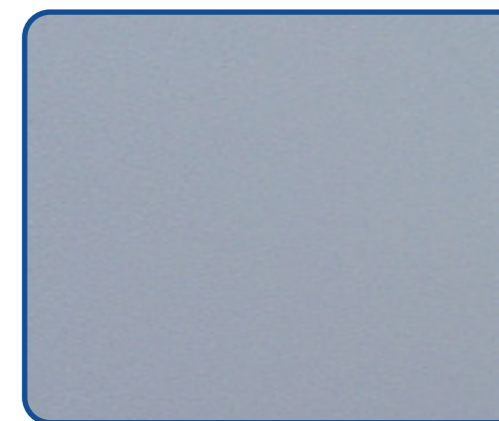

Sowaflex® - the professional internal cladding

- ▶ Highly puncture and scratch resistant
- ▶ 60% lighter than wood
- ▶ Damp-proof and resistant to oil, petrol and most chemicals
- ▶ 100% recyclable honeycomb material
- ▶ Quick installation by a clip and screw system using pre-determined locations in the bodywork
- ▶ Pre-cut for all vehicle models
- ▶ Reduction of vibration, and temperature stress with Sowafix.

All prices plus VAT and shipping. Our delivery and payment terms are applicable. See: www.sortimo.com/GTCT. Prices are only applicable for orders within Germany.

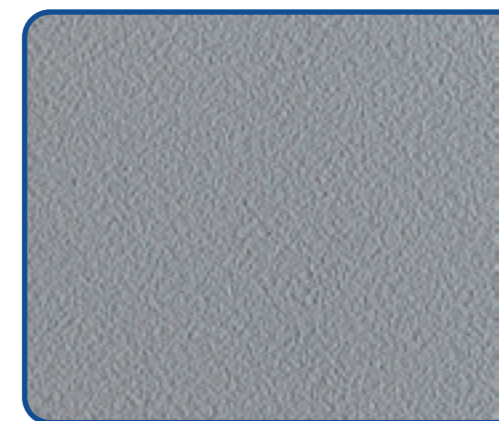

We have tested the pullout strength of our fixings to ensure safety.

The Sowafix® washers hold the Sortimo wall covering securely in position.

Floor plates



Floors for vans are supplied with cut outs for sliding side doors on the left and/or right side. For estate car applications floors are supplied for the boot area only or the boot area + rear seat area.

When ordering a floor plate, please keep in mind:

Unless otherwise specified, floors are based on single rear wheels and two wheel drive.

As a rule the sliding door is normally located on the right hand side. The floors will therefore be normally designed to meet an entry point on the right side. Floors for vehicles with sliding doors on both sides are available on request.

Wall cladding

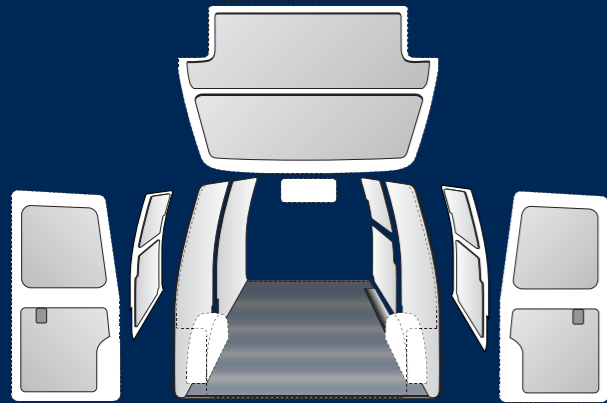

The cladding protects the entire interior, including sliding doors, rear doors or tailgate!

All parts are manufactured individually for each vehicle model.



The Sortimo safety packages

- ▶ Effective body protection from the inside, which is especially an advantage for leased vehicles! Additional lashing possibilities on the floor and wall in the loading area.

The Sortimo value-added benefit

- ▶ Attractive product range. Complete packages with further price benefit.

The Sortimo quality benefit

- ▶ Top quality from the market leader for professional in-vehicle equipment.
- ▶ Floor and wall are available cut-to-fit for most all vehicles.
- ▶ Can be retrospectively installed in existing vehicles as well as in new vehicles.
- ▶ Easy ordering and fast delivery nationwide.
- ▶ The safety package is compatible with the Sortimo in-vehicle equipment.
- ▶ Expert advice on all aspects of load safety



Safe and secure fastening

Securely fit equipment for safe transportation

Not only the legislator demands correct load safety; also your own personal feeling of responsibility!

Sortimo offers a variety of products that make it possible for you to secure cargo properly.

Lashing tracks, straps, cargo bars, load security nets make it easy to provide the highest level of security in no time at all.



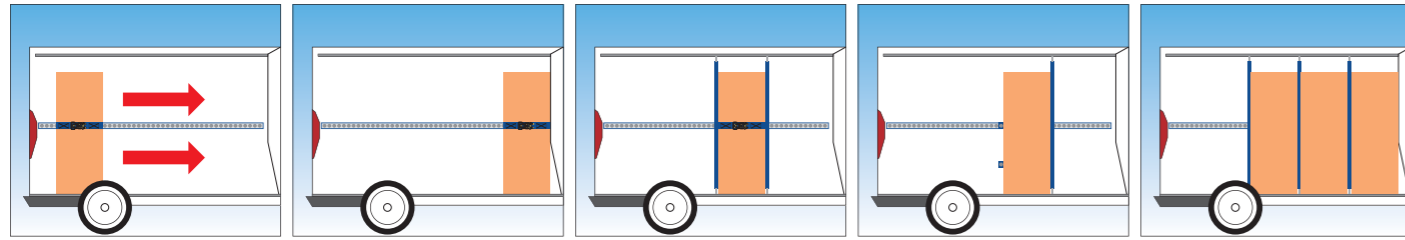

Free standing cargo in the vehicle creates a potentially serious hazard. Even secured with a lashing, the forces which can occur can not be easily subdued. Only the form fit – the flush fitting with the back wall or solid separating elements – can prevent the load slipping, tipping or

falling. The cargo bars from Sortimo fit individually into the rails in the floor and sidewall. They can be used both horizontally and vertically. Several pieces of cargo can therefore be securely fixed.

Securely fit equipment for safe transportation

Form fitting safety through structure

In form-fitting load safety, the cargo is loaded directly up to the front wall or against the side wall. If the vehicle body is supposed to secure the load, it must have the necessary capacity.

The European construction standard DIN EN 12642 sets out that the carrying capacity of the front wall must be 40%, the rear wall 25% and the side walls must be 30% of the payload.

If the cargo can not be loaded directly to the rear wall, variable form-fittings can be created with the aid of tools for example restraint poles.

These individual items of cargo can also be separated with cargo bars to generate more receiving points for the occurring forces.

Precondition is to equip the commercial vehicle from the outset with the best lashing rails and receiving points.

These can be on the vehicle itself or on the in-vehicle equipment.

Sortimo®

Practical Tips:

- ▶ Secure heavy cargo as low as possible and between the axles.
- ▶ Secure the cargo form-fitting/flush to the back wall or equipment.
- ▶ With anti-slip materials, enhance the friction of the load towards the floor.
- ▶ The Sortimo cargo bars can be used both horizontally and vertically.
- ▶ Heavy cargo may also be divided by a number of cargo bars.



Sortimo lashing and safety systems

The aluminium cargo bar

The Sortimo cargo bar is a universal instrument for securing loads. It may be deployed in the vehicle both horizontally and vertically, if the appropriate lashing tracks are attached. With their square floor plan, they securely hold the load in place. In the integrated tracks additional lashing straps with fittings can be used.

1

Cargo bar

A cargo bar made of aluminum with gas pressure spring for locking and securing of loads.

ZSPALU 2000 Ref. No. 801010150
Dimensions (WxDxH): 2000 x 45 x 40 mm
Weight: 3,79 kg

ZSPALU 3000 Ref. No. 801011361
Dimensions (WxDxH): 3000 x 45 x 40 mm
Weight: 5,20 kg

ZSPALU 1860 Ref. No. 801012835
Dimensions (WxDxH): 1860 x 45 x 40 mm
Weight: 4 x 3,59 kg

Suitable for the following vehicles:
MB Sprinter High roof H2
VW Crafter High roof H2
Fiat Ducato High roof H2
Citroën Jumper High roof H2
Peugot Boxer High roof H2

Please note: this version is only available in one package with 4 pieces.

ZSPALUP 3 Ref. No. 801012285
Dimensions (WxDxH): 3000 x 45 x 40 mm
Weight: 4,54 kg

Aluminum profiles for individual length adjustment usable as stop bars in connection with square brackets.

2

2 Square bracket

ZVKHL Ref. No. 801012339
For left lashing channel
Resilient to 450 daN
Inner dimensions: 42 x 46 x 36 mm

ZVKHR Ref. No. 801012338
For right lashing channel
Resilient to 450 daN
Inner dimensions: 42 x 46 x 36 mm

For loading wood or steel beams or plugging into a retractable aluminium lashing track as a pallet stopper

3

Protection against torsion

ZSPALUVDS Ref. No. 801013386
Dimensions (WxDxH): 69 x 38 x 20 mm
Weight: 0,08 kg

Aluminium cargo bar
Protection against torsion in the cargo bar



All prices plus VAT and shipping. Our delivery and payment terms are applicable.
See: www.sortimo.com/GTCT. Prices are only applicable for orders within Germany.

Sortimo lashing systems

Lashing Tracks

The lashing track can be variably affixed on the vehicle or affixed to the in-vehicle equipment. Sunk in the floor plate, they do not require space and are always ready to take lashing straps or cargo bars.

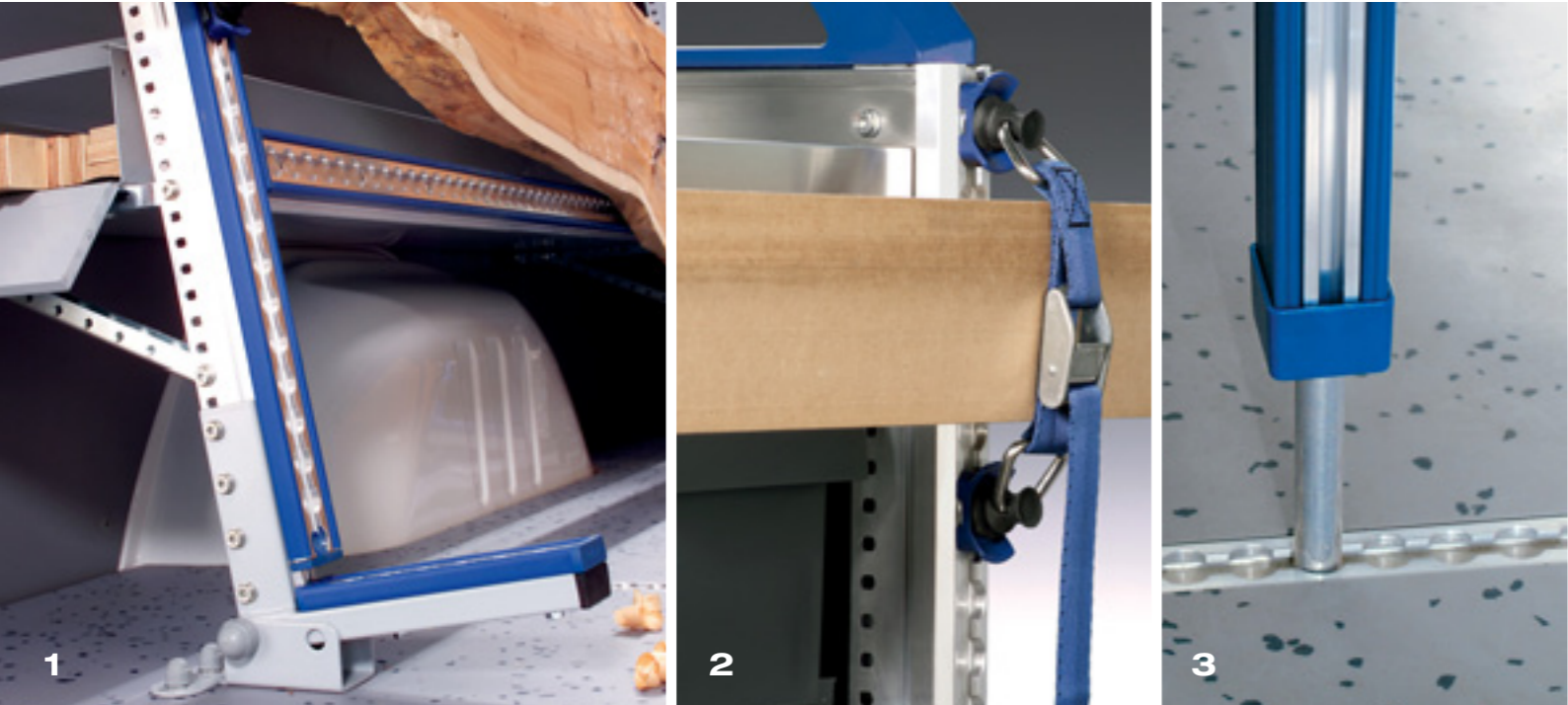

1 **Lashing tracks**

VZS 20-3	Ref. No. 801003320	Lashing track 20-3	Dimensions: 443 x 43 x 15 mm	Weight: 0,35 kg
VZS 30-3	Ref. No. 801003321	Lashing track 30-3	Dimensions: 685 x 43 x 15 mm	Weight: 0,55 kg
VZS 40-3	Ref. No. 801003864	Lashing track 40-3	Dimensions: 927 x 43 x 15 mm	Weight: 0,73 kg
VZS 50-3	Ref. No. 801003865	Lashing track 50-3	Dimensions: 1169 x 43 x 15 mm	Weight: 1,01 kg
VZS 60-3	Ref. No. 801003866	Lashing track 60-3	Dimensions: 1410 x 43 x 15 mm	Weight: 1,10 kg
VZS 120-3	Ref. No. 801003867	Lashing track 120-3	Dimensions: 3004 x 43 x 15 mm	Weight: 2,30 kg
SSA VZS	Ref. No. 71013290	Set of screws for lashing track		

The lashing tracks can be fixed to side walls, separating walls or on to the in-vehicle equipment.

4 **Aluminium lashing track**

ZSC 4D (Dach)	Ref. No. 801012921
Dimensions (WxDxH): 940 x 50 x 11,5 mm	
Weight: 0,8 kg	
ZSC 6	Ref. No. 801009978
Dimensions (WxDxH): 1500 x 50 x 11,5 mm	
Weight: 1,1 kg	
ZSC 12	Ref. No. 80714350
Dimensions (WxDxH): 3000 x 50 x 11,5 mm	
Weight: 2,2 kg	

Screw-on lashing tracks. Suitable for all aluminium cargo bars, lashing straps and eyes. DIN 75410-1

3/4 **Flush mounted lashing track**

ZSC 4A	Ref. No. 80779090
Dimensions (WxDxH): 940 x 65 x 11 mm	
Weight: 0,8 kg	
ZSC 12A	Ref. No. 80714398
Dimensions (WxDxH): 2990 x 65 x 11 mm	
Weight: 2,5 kg	
AZV 10-940	Ref. No. 801016060
Dimensions (WxDxH): 940 x 65 x 10 mm	
Weight: 0,8 kg	

Flush mounted aluminium lashing tracks for the Soboflex safety floor. Suitable for all aluminium cargo bars, lashing straps and eyes. DIN 75410-1

Perforated track

ZLC 6	Ref. No. 801006651
Dimensions (WxDxH): 1585 x 45 x 2 mm	
Weight: 0,45 kg	

The flush mounted perforated track for aluminium cargo bars can be integrated in Soboflex or Sobogrip safety floors. It is also suitable for the original wood floors from the vehicle manufacturer.

2 **Lashing track for uprights**

VZSPH 118	Ref. No. 801007173
Dimensions (WxDxH): 2006 x 32 x 19 mm	

Lashing track for rear uprights

Now you can also lash and safely transport cartons, window frames etc. The lashing track can be assembled with just one upright from the Globelyst System.

All prices plus VAT and shipping. Our delivery and payment terms are applicable. See: www.sortimo.com/GTCT. Prices are only applicable for orders within Germany.

Sortimo lashing systems

The lashing straps

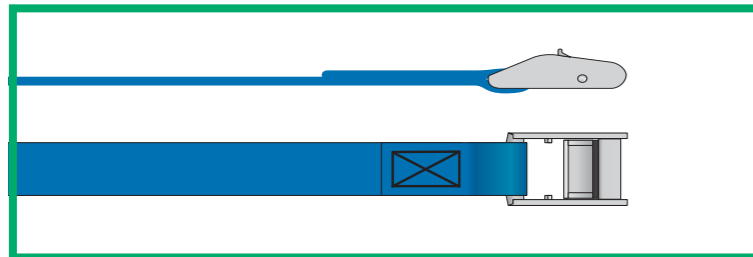

Lashing strap with lock buckle

Lashing strap with lock buckle
 Breaking strain 400 daN
 Strap approx. 3.5 m long x 25 mm wide, 100 % polyester

ZVK Ref. No. 80714114

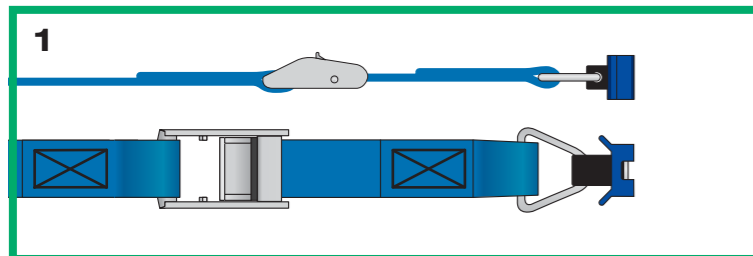

Lashing strap with lock buckle + fitting

Lashing strap w. lock buckle + fitting
 Breaking strain 200 daN,
 Strap approx. 2.1 m long x 25 mm wide, 100 % Polyester

ZVKF Ref. No. 801006833

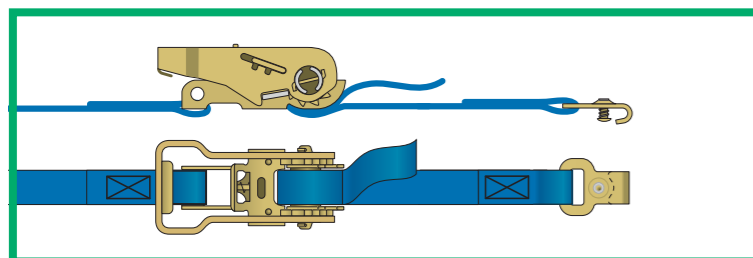

Lashing strap with ratchet

Lashing strap with ratchet and hook
 Breaking strain 650 daN
 Strap approx. 3.5 m long x 25 mm wide, 100 % Polyester

ZVRH Ref. No. 49717092

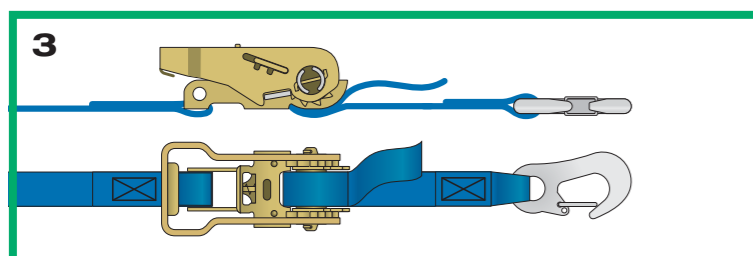

Lashing strap with ratchet

Lashing strap with ratchet and snap hook
 Breaking strain 800 daN
 Strap approx. 3.5 m long x 25 mm wide, 100 % Polyester

ZVRK Ref. No. 80714091 Length ca. 3,5 m

ZVRK6 Ref. No. 801016217 Length ca. 6,0 m

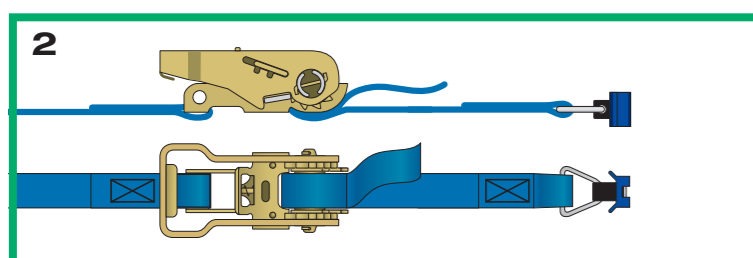

Lashing strap for tracks

Lashing strap with ratchet and fittings
 Breaking strain 400 daN, two end fittings to fit into Sortimo aluminium lashing track, Strap approx. 3.5 m long x 25 mm wide 100% Polyester

ZVRF Ref. No. 80714343 Length ca. 3,5 m

ZVRF6 Ref. No. 801016218 Length ca. 6,0 m

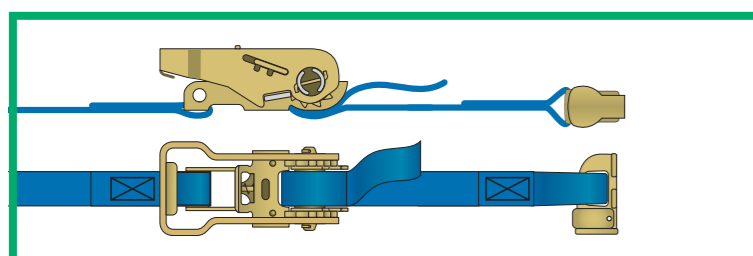

Lashing strap for tracks

Lashing strap with ratchet and track fittings and heavy load fitting
 Breaking strain 1000 daN, two end fittings to fit into Sortimo aluminium lashing track, Width 50 mm, 100 % Polyester

ZVRF 1000 Ref. No 801012959 Length ca. 3,0 m



All prices plus VAT and shipping. Our delivery and payment terms are applicable. See: www.sortimo.com/GTCT. Prices are only applicable for orders within Germany.



Anti slip protective corners

ZKSK VPE4 Ref. No. 801014004

The anti-slip protective corners made of plastic secure your load against slipping. Belts up to a width of 100mm are useable. For stabilization the belts can be fed into the corners.

VPE: 4 pieces



Lashing strap bag

ZVZGT 04-28 Ref. No. 801013271

Dimensions (WxDxH): 350 x 467 x 50 mm

Always clean and tidy Practical lashing strap bag for up to 4 lashing straps, Can be fastened to in-vehicle equipment or vehicle.

See picture page 21



Sortimo lashing systems

Lashing accessories



Single lashing point

ZEZP Ref. No. 801008097
Weight: 0,05 kg

Single lashing point to be screwed to upright or into floor, aluminium cargo bar, etc.



Lashing eye

ZGF Ref. No. 801009980
Weight: 0,04 kg

Lashing eye for variable usage with lashing straps on a track



Clamp fitting

ZHF Ref. No. 801007102
Weight: 0,16 kg

To be screwed to track, lashing straps can be hanged individually



Fitting with handle clamp

ZSC G Ref. No. 80778826
Weight: 0,11 kg

Use with track and channel



Fitting with stud and nut

ZSC M Ref. No. 80778819
Weight: 0,04 kg

Use with track and channel



Fitting with clamp nut

ZSC S Ref. No. 80715128
Weight: 0,08 kg

Use with track and channel in MB Viano



1 Load security net

ZLSN 1,7 x 1,1 Ref. No. 801002660
Dimensions (LxW): 1775 x 1150 mm

To safely transport goods in the aisle between equipment

ZLSN 1,4 x 1 Ref. No. 801012744
Dimensions (LxW): 1400 x 1025 mm

for Renault Kangoo, VW Caddy, Citroën Berlingo etc.

ZLSN 2,2 x 1,6 Ref. No. 801012746
Dimensions (LxW): 2275 x 1650 mm

for VW T5, MB Sprinter etc.

VDI 2700 tested



Floor lashing point set

VZA Ref. No. 80714244

For Soboflex safety floors – fit the nut inserts in required position in the walkway area. Pull out rating: 400 daN (kp) when using Soboflex®-safety floors. Kit includes two lashing points and 2 drive-in nuts



Lashing point

VZA2 Ref. No. 801009977

1 Lashing point
1 Lashing for fixing in Sortimo safety floor.



Flush lashing point

ZZM Ref. No. 80714015

Dimensions (LxW): 104 x 70 mm max. pull out rating 350 daN (kp)

Fitted countersunk in Soboflex®-safety flooring and firmly screwed to vehicle floor. Delivery includes fixings set.



Strap hook

ZHSB Ref. No. 80714121

Strap hook with safety stop. Can be retro fitted on a lashing strap. Breaking strain 750 daN



Fixing rails

ZFL Ref. No. 80714206

Fixing rail made of plastic. Can be screwed to the vehicle floor. Prevents cargo slipping on the vehicle floor.



Anti slip protective corners

LSE Ref. No. 801012678

Dimensions (WxLxD): 103 x 103 x 65 mm

Sturdy powder-coated metal corner with non-slip surface. The 4 anti-slip protective corners secure your load against slipping.



Rubber strap

ZLEIGS Ref. No. 80778925
Dim. (LxW): 2 m x 3 cm with 4 hooks

ZLEIG Ref. No. 801010020
Dim. (LxW): 10 m x 3 cm

ZLEIGH Ref. No. 80778963
20 hook pack for rubber mesh strap

All prices plus VAT and shipping. Our delivery and payment terms are applicable. See: www.sortimo.com/GTCT. Prices are only applicable for orders within Germany.

Correct fastening and lashing

With direct lashing the cargo will not be pressed onto the floor by the lashings, but held in position when it would otherwise move because of the dynamic drive forces.

When lashing diagonally and laterally the lashings are used in a straight train and anchored to lashing points on the cargo and on the loading surface.

When lashing with slings, lashing points on the cargo are not necessary. In all types of direct lashing the lashings should only be lightly tensioned.

When lashing diagonally, there are several possibilities: Four lashings are necessary, which should not cross each other.

In the way you attach the lashings, the lashing angles will be established; these angles have a large impact on the security provided by the lashings.

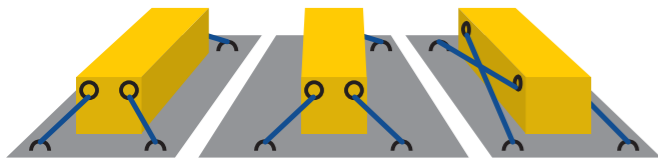

The head slings can also be used in different ways. The head sling serves as the end wall replacement, when for example the load is not loaded in a form fitting way, due to the distribution of the weight. The lashings are used as a loop in the front or the back of a load and fixed to the vehicle by lashing points.



Sortimo®

Practical Tips

- ▶ The use of a head or support sling provides additional points for lashing straps.
- ▶ A pallet can serve as a front wall replacement when lashing.
- ▶ Please always observe the details of the maximum load on the belt before use.



Head sling

RS 2T 2M Ref. No. 801015075

Head sling, total length 2 m

RS 2T 3M Ref. No. 801015076

Head sling, total length 3 m

RS 2T 4M Ref. No. 801015077

Head sling, total length 4 m



Anti-slip mat pallet

ZARM VPE4 Ref. No. 801014002

Dimensions (WxDxL): 200 x 100 x 8 mm

Four sturdy floor mats to increase the coefficient of friction between the load and the vehicle floor.

All prices plus VAT and shipping. Our delivery and payment terms are applicable. See: www.sortimo.com/GTCT Prices are only applicable for orders within Germany.

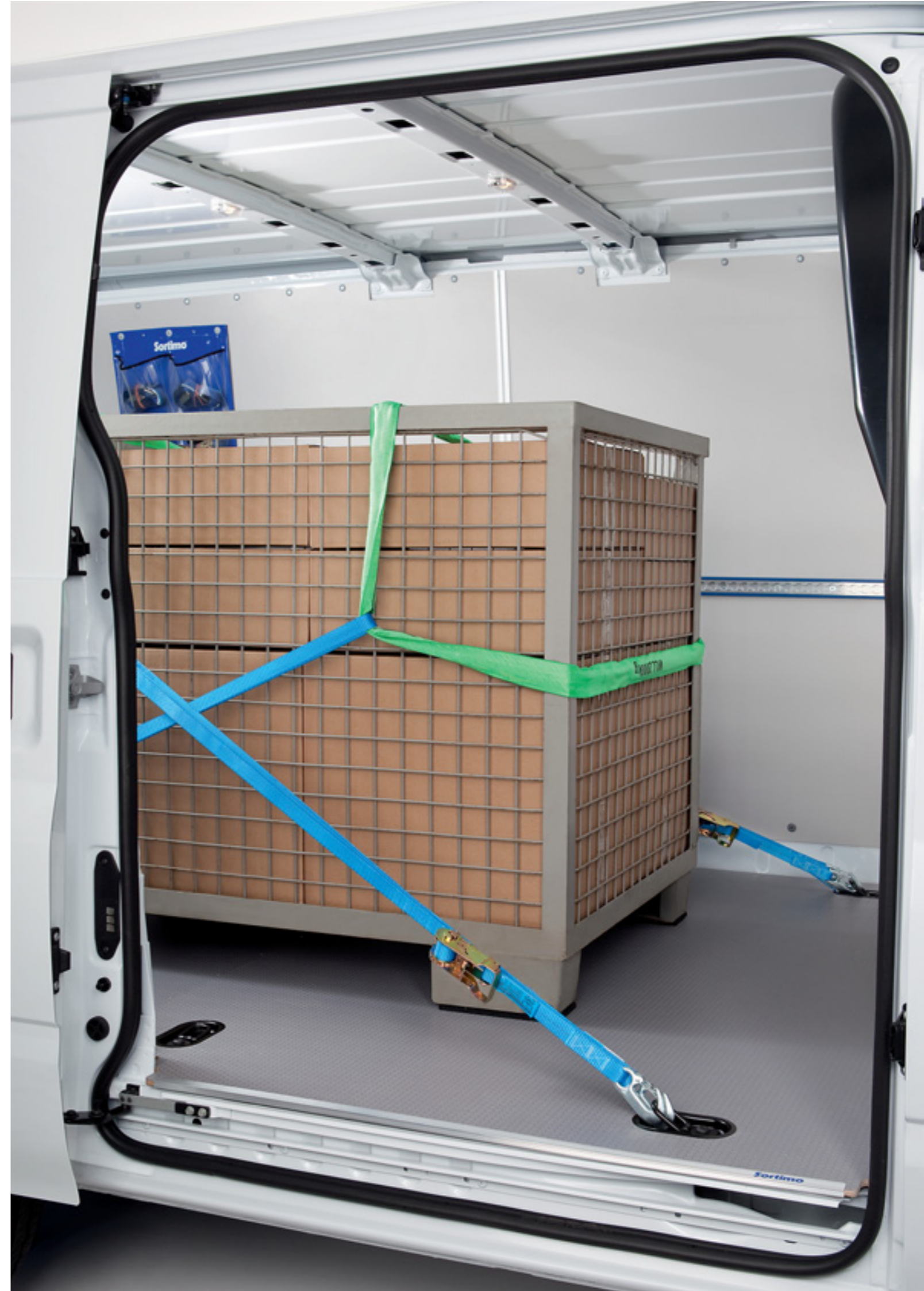



The Sortimo express shelving system

Express Safety

When time is short, safety can often be overlooked. The Sortimo express shelving system has been developed especially to meet the needs of the package carrier and courier operations. The shelf is easy and quick to install and adjust in order to meet your daily applications. It is the ideal solution for general delivery, courier service, E-commerce home deliveries and catering vans among others. Folded upwards the shelves lock into the uprights. The now visible lashing channels can be used to securely fasten even large pieces of cargo.

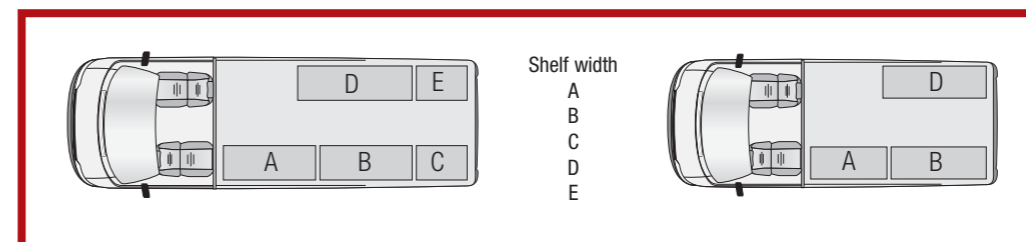

Vehicle Type	Wheel-base	Roof High	Up-right in mm	Shelf widths				
				A	B	C	D	E
Citroën Jumper/ Fiat Ducato/ Peugeot Boxer	3450	Medium	1830	1228	1228		1228	
Citroën Jumper/ Fiat Ducato/ Peugeot Boxer	4035	High	1935	1528	1528		1628	
Ford Transit	3300	Medium/High	1620	1028	1228		1228	
Iveco Daily (reduced loading area)	3000	Standard	1515	1028	1228		1228	
Iveco Daily	3300	Medium	1830	1228	1828		1828	
Iveco Daily	3300	High	2040	1228	1828		1828	
Iveco Daily	3950	Medium	1830	1528	1528	1028	1528	1028
Iveco Daily	3950	High						
Opel Movano/ Renault Master/ Nissan Interstar	3078	Standard	1620	1228	828		1028	
Opel Movano/ Renault Master/ Nissan Interstar	3078	Medium	1830	1228	828		1028	
Opel Vivaro/ Renault Trafic/ Nissan Primastar	3498	High	1725	1028	1028		1028	
VW Crafter/MB Sprinter	3250	Standard	1515	1028	1028		1028	
VW Crafter/MB Sprinter	3665	Standard	1515	1228	1628		1528	
VW Crafter/MB Sprinter	3665	High	1725	1228	1628		1528	

More vehicle types are available on request!



You want to know more about the Sortimo Express shelf, then please call us on phone **+49 8291 850-459** or fax us **+49 8291 850-249**.

The Sortimo MultiRack

The variable racking system for very special transportation needs.

The Sortimo MultiRack is the perfect solution for the efficient transportation of goods such as flowers or other delicate materials. Perfect for catering, gardeners, florists, painters or pharmacy delivery services among others.

Easily installed it turns your commercial vehicle into a multileveled van. If you remove the trays you once again have room in your vehicle for big and bulky goods.

- ▶ Tray dimensions: 893 x 893 mm, 993 x 993 or 1093 x 1093 mm
- ▶ High-performance studded finish
- ▶ Impact resistant and scratch-proof
- ▶ Resistant to stains and easily cleaned
- ▶ Aluminium border and plastic corner strips
- ▶ Individual height adjustment
- ▶ Load capacity of up to 120 kg per tray
- ▶ Rearward extendable



You want to know more about the Sortimo Multirack. Our advisors and in-vehicle equipment designers are available to individually design your equipment.



Sortimo MultiRack

- | | |
|----------------------|-----------------------|
| Citroën Berlingo | Opel Vivaro |
| Citroën Jumpy | Peugeot Bipper |
| Citroën Nemo | Peugeot Expert |
| Fiat Doblò | Peugeot Partner |
| Fiat Fiorino | Renault Kangoo |
| Fiat Scudo | Renault Trafic |
| Ford Transit Connect | Volkswagen Caddy |
| Mercedes-Benz Vito | Volkswagen Caddy Maxi |
| Nissan Primastar | Volkswagen T5 |

- Delivery:
- ▶ 4 supports
 - ▶ 2 trays
 - ▶ 1 Sobogrip®-safety floor
 - ▶ 1 load security net (optional)

You want to know more about the Sortimo MultiRack, then please call us on phone **+49 8291 850-459** or fax us **+49 8291 850-249**.

All prices plus VAT and shipping. Our delivery and payment terms are applicable. See: www.sortimo.com/GTCT. Prices are only applicable for orders within Germany.





The professional equipment for utility vehicles

Perfect load safety with Sortimo In-Vehicle Equipment

For more than 35 years Sortimo has been the innovative force for professional in-vehicle equipment.

The Globelyst system provides for all industry-specific requirements, the best solution to ensure safe transportation. Whether screws, cases, machines or tools – everything finds its place – safe and tidy.

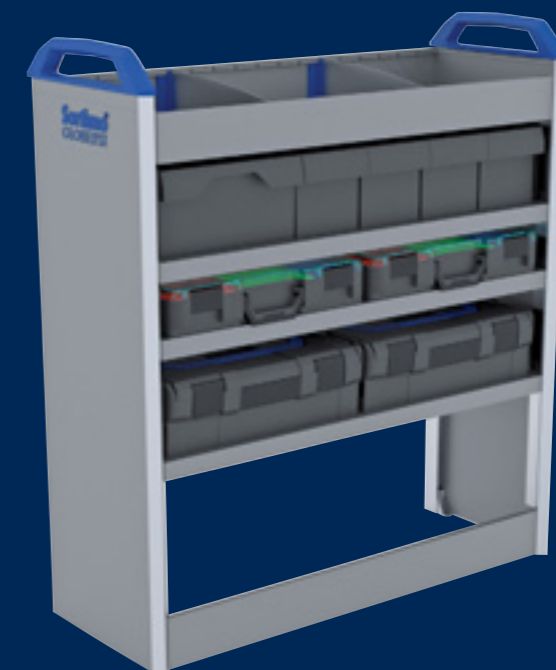



Sortimo Globelyst – the interior designer for your vehicle

Individual Globelyst planning for your personal in-vehicle solutions

With our 3D design configurator we can meet all your needs. We plan your individual in-vehicle equipment according to your precise requirements.



More safety and optimal working conditions at the same time

No other load safety system offers as many possibilities as the Sortimo professional in-vehicle equipment. No matter what you want to transport, for all requirements, we have the right solution at hand.

From the smallest spare part to cases, from the washing machine to the compressor everything can be stowed safely. The other advantages are obvious: No more unnecessary time spent searching, perfect overview and thus faster work makes Sortimo's in-vehicle equipment an indispensable partner in your daily work.



Sortimo Globelyst – Pre-assembled shelves and blocks



Mini-blocks by Sortimo



Mini-block BLM 24-37
Ref. No. 291006532
 Dim. (WxDxH): 520 x 382 x 638 mm
 Weight: 12,3 kg

- ▶ 1 Worktop
- ▶ 3 M-BOXXes without lid
- ▶ Fastenings

It is also possible to fit M-BOXXes with a handle.



Mini-block BLS 24-28
Ref. No. 291006531
 Dim. (WxDxH): 520 x 382 x 485 mm
 Weight: 23 kg

- ▶ 1 Worktop
- ▶ 4 Drawers
- ▶ Fastenings



Mini-block BLK 24-28
Ref. No. 291006530
 Dim. (WxDxH): 520 x 382 x 485 mm
 Weight: 17,6 kg

- ▶ 1 Worktop
- ▶ 4 Case trays without cases
- ▶ Fastenings



Mini-block BLT 24-28
Ref. No. 291013458
 Dim. (WxDxH): 520 x 382 x 485 mm
 Weight: 10,4 kg

- ▶ 1 Worktop
- ▶ 4 pairs of case rails
- ▶ Fastenings

T-BOXXes not included in the delivery.



The combination block for estate cars fits in almost all vehicles



Mini-block BL 47-0/1
Ref. No. 291006686
 Dim. (WxDxH): 1004 x 694 x 442 mm
 Weight: 59 kg

- ▶ 1 Worktop
- ▶ 3 Drawers
- ▶ Fastenings

All prices plus VAT and shipping.
 Our delivery and payment terms are applicable. See: www.sortimo.com/GTCT
 Prices are only applicable for orders within Germany.

Pre-assembled Globelyst Blocks



Block BL 43-0/1

Ref. No. 291009752

Dimensions (WxDxH):
1004 x 278 x 1100 mm
Weight: 20 kg

- ▶ 2 Lashing tracks
- ▶ 1 Shelf tray with rim
- ▶ 6 Ratchet straps for refrigerant gas bottles
- ▶ Fastenings

The rack is ideal for storing refrigerant gas bottles.



Block BL 44-0/5

Ref. No. 291003955

Dimensions (WxDxH):
1004 x 382 x 981 mm
Weight: 57 kg

- ▶ 1 Lift up flap
- ▶ 3 Drawers
- ▶ 2 Service cases KM 321 E
- ▶ 1 Tool case WM 321
- ▶ 1 Shelf tray with dividers and anti-rattle mat
- ▶ Fastenings

The rack can be fitted on the left and right side above the wheel arch.

Citroën Jumper	as of yr. 06	4
Citroën Jumpy	as of yr. 07	4
Fiat Ducato	as of yr. 06	4
Fiat Scudo	as of yr. 07	4
Ford Transit Front	as of yr. 00	4
Ford Transit Rear	as of yr. 00	•
Iveco Daily	as of yr. 99	•
MB Sprinter	as of yr. 06	•
MB Vito	as of yr. 03	•
Nissan Primastar	as of yr. 02	•
Opel Vivaro	as of yr. 01	•
Peugeot Boxer	as of yr. 06	4
Peugeot Expert	as of yr. 07	4
Renault Trafic	as of yr. 01	•
Toyota Hiace	as of yr. 98	•
VW T5	as of yr. 03	•
VW Crafter	as of yr. 06	•

Further types of vehicle on request.



Block BL 44-0/2

Ref. No. 291003951

Dimensions (WxDxH):
1004 x 382 x 1185 mm
Weight: 34 kg

- ▶ 1 Lift up flap
- ▶ 3 Shelf trays with dividers and anti-rattle mats
- ▶ 1 Shelf with 6 S-BOXEs
- ▶ Fastenings

The rack can be fitted on the left and right side above the wheel arch.

Citroën Jumper	as of yr. 06	4
Citroën Jumpy	as of yr. 07	4
Fiat Ducato	as of yr. 06	4
Fiat Scudo	as of yr. 07	4
Ford Transit Front	as of yr. 00	4
Ford Transit Rear	as of yr. 00	•
Iveco Daily	as of yr. 99	•
MB Sprinter	as of yr. 06	•
MB Vito	as of yr. 03	•
Nissan Primastar	as of yr. 02	•
Opel Vivaro	as of yr. 01	•
Peugeot Boxer	as of yr. 06	4
Peugeot Expert	as of yr. 07	4
Renault Trafic	as of yr. 01	•
Toyota Hiace	as of yr. 98	•
VW T5	as of yr. 03	•
VW Crafter	as of yr. 06	•

Further types of vehicle on request.



Block BL 44-0/9

Ref. No. 291016138

Dimensions (WxDxH):
1004 x 382 x 1202 mm
Weight: 21 kg

- ▶ 1 Shelf tray with dividers and anti-rattle mat
- ▶ 1 Case clamp
- ▶ 1 basket shelf with divider
- ▶ Fastenings

The rack cannot be fitted above the wheel arch.

Citroën Jumper	as of yr. 06	•
Citroën Jumpy	as of yr. 07	•
Fiat Ducato	as of yr. 06	•
Fiat Scudo	as of yr. 07	•
Ford Transit Front	as of yr. 00	•
Ford Transit Rear	as of yr. 00	•
Iveco Daily	as of yr. 99	•
MB Sprinter	as of yr. 06	•
MB Vito	as of yr. 03	•
Nissan Primastar	as of yr. 02	•
Opel Vivaro	as of yr. 01	•
Peugeot Boxer	as of yr. 06	•
Peugeot Expert	as of yr. 07	•
Renault Trafic	as of yr. 01	•
Toyota Hiace	as of yr. 98	•
VW T5	as of yr. 03	•
VW Crafter	as of yr. 06	•

Further types of vehicle on request.



Block BL 44-0/4

Ref. No. 291003954

Dimensions (WxDxH):
1004 x 382 x 1100 mm
Weight: 72 kg

- ▶ 1 Base plinth
- ▶ 1 Slide out workbench
- ▶ 1 Vice ZSP 120
- ▶ 3 Drawers
- ▶ 1 Service case KM 321
- ▶ 1 Service case KM 332 F
- ▶ 1 Tool case WM 351
- ▶ 1 Shelf tray with divider and anti-rattle mat
- ▶ Fastenings

The block can be fitted above the wheel arch on the right-hand side only.

Citroën Jumper	as of yr. 06	4
Citroën Jumpy	as of yr. 07	•
Fiat Ducato	as of yr. 06	4
Fiat Scudo	as of yr. 07	•
Ford Transit Front	as of yr. 00	4
Ford Transit Rear	as of yr. 00	•
Iveco Daily	as of yr. 99	1
MB Sprinter	as of yr. 06	•
MB Vito	as of yr. 03	•
Nissan Primastar	as of yr. 02	•
Opel Vivaro	as of yr. 01	•
Peugeot Boxer	as of yr. 06	4
Peugeot Expert	as of yr. 07	•
Renault Trafic	as of yr. 01	•
Toyota Hiace	as of yr. 98	•
VW T5	as of yr. 03	•
VW Crafter	as of yr. 06	•

Further types of vehicle on request.



Block BL 44-0/10

Ref. No. 291016139

Dimensions (WxDxH):
1004 x 382 x 1270 mm
Weight: 25 kg

- ▶ 1 aluminium floor with divider and anti-rattle mat
- ▶ 1 Shelf tray with 4 S-BOXEs, and one wide S-BOX
- ▶ 1 Basket shelf with divider

The rack can be fitted on the left and right side above the wheel arch.

Citroën Jumper	as of yr. 06	4
Citroën Jumpy	as of yr. 07	•
Fiat Ducato	as of yr. 06	4
Fiat Scudo	as of yr. 07	•
Ford Transit Front	as of yr. 00	4
Ford Transit Rear	as of yr. 00	•
Iveco Daily	as of yr. 99	•
MB Sprinter	as of yr. 06	•
MB Vito	as of yr. 03	•
Nissan Primastar	as of yr. 02	•
Opel Vivaro	as of yr. 01	•
Peugeot Boxer	as of yr. 06	4
Peugeot Expert	as of yr. 07	•
Renault Trafic	as of yr. 01	•
Toyota Hiace	as of yr. 98	•
VW T5	as of yr. 03	•
VW Crafter	as of yr. 06	•

Further types of vehicle on request.

• Fits in the vehicle, 1) Wheelbase may affect right side installation
2) Install only on left side 3) Install only on right side 4) Caution: high wheel arch, please consult your Sortimo Partner

All prices plus VAT and shipping. Our delivery and payment terms are applicable.
See: www.sortimo.com/GTCT. Prices are only applicable for orders within Germany.

• Fits in the vehicle, 1) Wheelbase may affect right side installation
2) Install only on left side 3) Install only on right side 4) Caution: high wheel arch, please consult your Sortimo Partner

Pre-assembled Globelyst Blocks



Block BL 44-0/11

Ref. No. 291016140

Dimensions (WxDxH):
1004 x 382 x 1066 mm
Weight: 58 kg

- ▶ 1 Lift up flap
- ▶ Drawers
- ▶ Shelf tray with divider and anti-rattle mat
- ▶ 4 case drawers with 4 T-BOXXes
- ▶ Fastenings

The block can only be fitted above the wheel arch on the right.

Citroën Jumper	as of yr. 06	4
Citroën Jumpy	as of yr. 07	4
Fiat Ducato	as of yr. 06	4
Fiat Scudo	as of yr. 07	4
Ford Transit Front	as of yr. 00	4
Ford Transit Rear	as of yr. 00	•
Iveco Daily	as of yr. 99	•
MB Sprinter	as of yr. 06	•
MB Vito	as of yr. 03	•
Nissan Primastar	as of yr. 02	•
Opel Vivaro	as of yr. 01	•
Peugeot Boxer	as of yr. 06	4
Peugeot Expert	as of yr. 07	4
Renault Trafic	as of yr. 01	•
Toyota Hiace	as of yr. 98	•
VW T5	as of yr. 03	•
VW Crafter	as of yr. 96	•

Further types of vehicle on request.



Block BL 44-0/12

Ref. No. 291016141

Dimensions (WxDxH):
1004 x 382 x 1083 mm
Weight: 27 kg

- ▶ 1 Shelf tray with divider and anti-rattle mat
- ▶ 3 floors for 6 L-BOXXes 102
- ▶ Fastenings

The block can only be fitted above the wheel arch on the right.

Citroën Jumper	as of yr. 06	4
Citroën Jumpy	as of yr. 07	•
Fiat Ducato	as of yr. 06	4
Fiat Scudo	as of yr. 07	•
Ford Transit Front	as of yr. 00	4
Ford Transit Rear	as of yr. 00	•
Iveco Daily	as of yr. 99	•
MB Sprinter	as of yr. 06	•
MB Vito	as of yr. 03	•
Nissan Primastar	as of yr. 02	•
Opel Vivaro	as of yr. 01	•
Peugeot Boxer	as of yr. 06	4
Peugeot Expert	as of yr. 07	•
Renault Trafic	as of yr. 01	•
Toyota Hiace	as of yr. 98	•
VW T5	as of yr. 03	•
VW Crafter	as of yr. 96	•

Further types of vehicle on request.

L-BOXXes not included in delivery.



Block BL 54-0/3

Ref. No. 291003953

Dimensions (WxDxH):
1246 x 382 x 1185 mm
Weight: 52 kg

- ▶ 1 Lift up flap
- ▶ 3 Shelf trays with dividers and anti-rattle mats
- ▶ 4 case drawers with 4 T-BOXXes
- ▶ 3 floors for 7 S-BOXXes
- ▶ Fastenings

The block can only be fitted above the wheel arch on the right.

Citroën Jumper	as of yr. 06	4
Citroën Jumpy	as of yr. 07	4
Fiat Ducato	as of yr. 06	4
Fiat Scudo	as of yr. 07	4
Ford Transit Front	as of yr. 00	4
Ford Transit Rear	as of yr. 00	•
Iveco Daily	as of yr. 99	•
MB Sprinter	as of yr. 06	•
MB Vito	as of yr. 03	1
Nissan Primastar	as of yr. 02	1
Opel Vivaro	as of yr. 01	1
Peugeot Boxer	as of yr. 06	4
Peugeot Expert	as of yr. 07	4
Renault Trafic	as of yr. 01	1
Toyota Hiace	as of yr. 98	1
VW T5	as of yr. 03	1
VW Crafter	as of yr. 96	•

Further types of vehicle on request.

- Fits in the vehicle
- 1) Wheelbase may affect right side installation
- 2) Install only on left side
- 3) Install only on right side
- 4) Caution: high wheel arch, please consult your Sortimo Partner



Block BL 54-0/7

Ref. No. 291003957

Dimensions (WxDxH):
1246 x 382 x 1015 mm
Weight: 75 kg

- ▶ 1 Lift up flap
- ▶ 3 Drawers
- ▶ 1 Service case KM 321 E
- ▶ 1 Twin level case DM 332 E
- ▶ 1 Tool case WM 331
- ▶ 1 Shelf tray with dividers and anti-rattle mats
- ▶ Fastenings

The rack can be fitted on the left and right side above the wheel arch.

Citroën Jumper	as of yr. 06	4
Citroën Jumpy	as of yr. 07	-
Fiat Ducato	as of yr. 06	4
Fiat Scudo	as of yr. 07	-
Ford Transit Front	as of yr. 00	4
Ford Transit Rear	as of yr. 00	•
Iveco Daily	as of yr. 99	•
MB Sprinter	as of yr. 06	•
MB Vito	as of yr. 03	1
Nissan Primastar	as of yr. 02	1
Opel Vivaro	as of yr. 01	1
Peugeot Boxer	as of yr. 06	4
Peugeot Expert	as of yr. 07	-
Renault Trafic	as of yr. 01	1
Toyota Hiace	as of yr. 98	1
VW T5	as of yr. 03	1
VW Crafter	as of yr. 06	•

Further types of vehicle on request.

All prices plus VAT and shipping. Our delivery and payment terms are applicable. See: www.sortimo.com/GTCT. Prices are only applicable for orders within Germany.

- Fits in the vehicle, 1) Wheelbase may affect right side installation
- 2) Install only on left side 3) Install only on right side 4) Caution: high wheel arch, please consult your Sortimo Partner

Pre-assembled Globelyst Blocks



Block BL 64-0/6

Ref. No. 291003956

Dimensions (WxDxH):
1488 x 382 x 1185 mm
Weight: 58 kg

- ▶ 1 Lift up flap
- ▶ 3 Shelf trays with dividers and anti-rattle mats
- ▶ 1 Shelf with 9 S-BOXes
- ▶ Fastenings

The block can only be fitted above the left wheel arch.

Citroën Jumper	as of yr. 06	4/1
Citroën Jumpy	as of yr. 07	4/2
Fiat Ducato	as of yr. 06	4/1
Fiat Scudo	as of yr. 07	4/2
Ford Transit Front	as of yr. 00	4/1
Ford Transit Rear	as of yr. 00	1
Iveco Daily	as of yr. 99	1
MB Sprinter	as of yr. 06	1
MB Vito	as of yr. 03	2
Nissan Primastar	as of yr. 02	2
Opel Vivaro	as of yr. 01	2
Peugeot Boxer	as of yr. 06	4/1
Peugeot Expert	as of yr. 07	4/2
Renault Trafic	as of yr. 01	2
Toyota Hiace	as of yr. 98	2
VW T5	as of yr. 03	2
VW Crafter	as of yr. 06	1

Further types of vehicle on request.



Block BL 64-0/11

Ref. No. 291016142

Dimensions (WxDxH):
1488 x 382 x 1083 mm
Weight: 36 kg

- ▶ 1 Shelf tray with dividers and anti-rattle mats
- ▶ 2 floors for 9 L-Boxes 102
- ▶ 1 floor for 3 L-Boxes 238
- ▶ Fastenings

The rack can be fitted on the left and right side above the wheel arch.

Citroën Jumper	as of yr. 06	4/1
Citroën Jumpy	as of yr. 07	2
Fiat Ducato	as of yr. 06	4/1
Fiat Scudo	as of yr. 07	2
Ford Transit Front	as of yr. 00	4/1
Ford Transit Rear	as of yr. 00	1
Iveco Daily	as of yr. 99	1
MB Sprinter	as of yr. 06	1
MB Vito	as of yr. 06	1
Nissan Primastar	as of yr. 02	2
Opel Vivaro	as of yr. 01	2
Peugeot Boxer	as of yr. 06	4/1
Peugeot Expert	as of yr. 07	2
Renault Trafic	as of yr. 01	2
Toyota Hiace	as of yr. 98	2
VW T5	as of yr. 03	2
VW Crafter	as of yr. 06	1

L-Boxes not included in the delivery.

Further types of vehicle on request.

All prices plus VAT and shipping. Our delivery and payment terms are applicable. See: www.sortimo.com/GTCT. Prices are only applicable for orders within Germany.

- Fits in the vehicle, 1) Wheelbase may affect right side installation
- 2) Install only on left side 3) Install only on right side 4) Caution: high wheel arch, please consult your Sortimo Partner



Block BL 64-0/9

Ref. No. 291003959

Dimensions (WxDxH):
1488 x 382 x 1440 mm
Weight: 86 kg

- ▶ 1 Lift up flap
- ▶ 5 Drawers
- ▶ 2 Shelf trays with dividers and anti-rattle mats
- ▶ 1 Shelf with 9 S-BOXes
- ▶ Fastenings

The block can be only be fitted above the left wheel arch.

Citroën Jumper	as of yr. 06	4/1
Citroën Jumpy	as of yr. 07	-
Fiat Ducato	as of yr. 06	4/1
Fiat Scudo	as of yr. 07	-
Ford Transit Front	as of yr. 00	4/1
Ford Transit Rear	as of yr. 00	1
Iveco Daily	as of yr. 99	1
MB Sprinter	as of yr. 06	1
MB Vito	as of yr. 03	2
Nissan Primastar	as of yr. 02	2
Opel Vivaro	as of yr. 01	2
Peugeot Boxer	as of yr. 06	4/1
Peugeot Expert	as of yr. 07	-
Renault Trafic	as of yr. 01	2
Toyota Hiace	as of yr. 98	2
VW T5	as of yr. 03	2
VW Crafter	as of yr. 06	1

Further types of vehicle on request.



Block BL 64-0/10

Ref. No. 291003960

Dimensions (WxDxH):
1488 x 382 x 1049 mm
Weight: 91 kg

- ▶ 1 Lift up flap
- ▶ 3 Drawers
- ▶ 1 Tool case WM 351
- ▶ 1 Machine case MM 350
- ▶ 1 Service case KM 321 E
- ▶ 1 Service case KM 332 F
- ▶ 1 Twin level case DM 342 E
- ▶ 1 Shelf tray with 4 dividers
- ▶ Fastenings

The block can only be fitted above the wheel arch on the left.

Citroën Jumper	as of yr. 06	4/1
Citroën Jumpy	as of yr. 07	-
Fiat Ducato	as of yr. 06	4/1
Fiat Scudo	as of yr. 07	-
Ford Transit Front	as of yr. 00	4/1
Ford Transit Rear	as of yr. 00	1
Iveco Daily	as of yr. 99	1
MB Sprinter	as of yr. 06	1
MB Vito	as of yr. 03	2
Nissan Primastar	as of yr. 02	2
Opel Vivaro	as of yr. 01	2
Peugeot Boxer	as of yr. 06	4/1
Peugeot Expert	as of yr. 07	-
Renault Trafic	as of yr. 01	2
Toyota Hiace	as of yr. 98	2
VW T5	as of yr. 03	2
VW Crafter	as of yr. 06	1

Further types of vehicle on request.



The Sortimo Easy-Klick®-System



Flexibility is everything!

You want an in-vehicle equipment solution but you also want to remain flexible enough to use your complete stowage area when needs be? Then we have just the solution for you. Easy-Klick® by Sortimo gives you the choice.

You are visiting a customer and want to have your workshop with you. No problem: simply roll the equipment block into position inside the vehicle, "click-in" to the anchoring point and fasten the safety belt to the floor. Everything is safely in place.

The next day you need the vehicle empty for transporting bulky cargo. Very easy – simply unclick and the secure equipment block is released from the anchoring point, and can now be removed from the vehicle. After finishing your work you can simply put the block back in its place.

On the next page you can see a few examples of pre-assembled roll containers with the Easy-Klick® system.



An additional safety feature: The Easy-Klick safety belt connection between the equipment block and the floor insert.



Loading ramps

	ZVS 2000 Ref. No. 801009243 Weight: 16,0 kg 1 pair loading rails 2000 mm
	ZVSF 2000 Ref. No. 801009244 Weight: 18,0 kg 1 pair loading rails 2000 mm, foldable
	ZVS 2500 Ref. No. 801009245 Weight: 20,0 kg 1 pair loading rails 2500 mm
	ZVSF 2500 Ref. No. 801009246 Weight: 22,0 kg 1 pair loading rails 2500 mm, foldable

Aluminium loading rails with protective strip. Non-slip surface P13. Inner width 150 mm, outer width 234 mm. Height of protective strips 30/42 mm. Carrying capacity, folding version 300 daN/kp. Carrying capacity non-folding version 380 daN/kp

Roll containers with the Easy-Klick® system Fits most car models



Roll container BL 25-0/2
Ref. No. 291009755
Dim. (W x D x H): 570 x 526 x 1128 mm
Weight: 32 kg

- ▶ 2 Swivel castors without and
- ▶ 2 Swivel castors with brake
- ▶ 3 shelves with rim
- ▶ 1 Roller shutter
- ▶ 1 Shelf tray with 1 divider and anti-rattle mat
- ▶ 1 Easy-Klick® quick change adaptor set



Roll container BL 25-0/1
Ref. No. 291009754
Dim. (W x D x H): 570 x 526 x 1128 mm
Weight: 38 kg

- ▶ 2 Swivel castors without and
- ▶ 2 Swivel castors with brake
- ▶ 1 Cupboard with door
- ▶ 3 Drawers
- ▶ 1 Shelf tray with 1 divider and anti-rattle mat
- ▶ 1 Easy-Klick® quick change adaptor set



Roll container BL 24-0/1
Ref. No. 291009756
Dim. (W x D x H): 570 x 422 x 1128 mm
Weight: 22,6 kg

- ▶ 2 Swivel castors without and
- ▶ 2 Swivel castors with brake
- ▶ 4 M-BOXEs without lid
- ▶ 1 Shelf tray with 1 divider and anti-rattle mat
- ▶ 1 Easy-Klick® quick change adaptor set



All prices plus VAT and shipping. Our delivery and payment terms are applicable. See: www.sortimo.com/GTCT Prices are only applicable for orders within Germany.



The Sortimo XL-Drawers

The twin floor for when you're on the road

Especially in vans we have no space to give away. This can be influenced of course by the correct distribution of space because as everyone knows you can always make more room.

The new XL-drawers from Sortimo simply lift the floor, making room for the practical and very deep drawers to a depth of 1.19m.

Now put the in-vehicle equipment from the Globelyst programme onto the safety floor and you are ready to go. You will be surprised how much you can fit into your vehicle. So who is talking about a small commercial vehicle now?



XL-Drawer L

Weight: ca. 78 kg

- ▶ 3 drawers
- ▶ 1 Soboflex® cover plate
- ▶ Sobogrip® floor insert

Price on request according to type of vehicle.



XL-Drawer S

Weight: ca. 93 kg

Top: Rack

- ▶ 2 shelf trays with 3 dividers and anti-rattle mats

Bottom: XL-drawer

- ▶ 3 drawers
- ▶ 1 Soboflex® cover plate
- ▶ Sobogrip® floor insert

Price on request according to type of vehicle.



XL-Drawer P

Weight: ca. 102 kg

Top: Rack

- ▶ 2 M-BOXes
- ▶ 1 aluminium box floor with 4 S-BOXes
- ▶ 1 shelf tray with 2 dividers and anti-rattle mat
- ▶ 2 shelves with rim, dividers and anti-rattle mats
- ▶ 1 lashing strap

Bottom: XL-Drawer

- ▶ 3 drawers
- ▶ Soboflex® cover plate
- ▶ Sobogrip® floor insert

Price on request according to type of vehicle.

Suitable for the following vehicle types:

- ▶ Citroën Berlingo
- ▶ Fiat Doblò
- ▶ Ford Transit Connect
- ▶ Opel Combo
- ▶ Peugeot Bipper
- ▶ VW Caddy
- ▶ Citroën Nemo
- ▶ Fiat Fiorino
- ▶ Nissan Kubistar
- ▶ Peugeot Partner
- ▶ Renault Kangoo

The universal loading platform

Loading made easy

Anybody who works hard can use a little help with loading. The smaller the vehicle, the more difficult it is to load and unload. With the universal loading platform (load capacity of up to 250kg) Sortimo offers an ideal solution for estate cars and small vans. Simply pull out the loading platform; now you can load and unload comfortably and access all the tools stored in the drawers, is a great safety feature for those with a bad back.

Once the loading platform has been pushed back into the vehicle it automatically locks in the closed position. Your load is safely stored. Crash tests have proven impressively that this adds enormously to passive safety. Once you have worked with this system you will never again want to do without this comfort.

Let our loading platform take the strain as life is difficult enough!
Your back will thank you.

You want to know more about the universal loading platform, then please call us on **+49 8291 850-459** or fax us **+49 8291 850-249**.



All prices plus VAT and shipping.
Our delivery and payment terms are applicable. See: www.sortimo.com/GTCT
Prices are only applicable for orders within Germany.

Sortimo Globelyst Supplement parts

Dividers and anti rattle mats for shelf trays



Divider holder rear

TBH FW H Ref. No. 401002974

Divider holder FW Blue rear
Necessary for all shelf trays



Divider holder front

TBH FW V Ref. No. 401002972

Divider holder FW Blue front
Necessary for all shelf trays and shelf floors with rim



Dividers for shelf trays

TB FW 3	Ref. No. 401002730	Divider FW 03-0
TB FW 4	Ref. No. 401002731	Divider FW 04-0
TB FW 5	Ref. No. 401002733	Divider FW 05-0
TB FW 7	Ref. No. 401005309	Divider FW 07-0



Dividers for shelves with rim

TB FR 3	Ref. No. 401010278	Divider FR 03-0
TB FR 4	Ref. No. 401010279	Divider FR 04-0
TB FR 5	Ref. No. 401010280	Divider FR 05-0
TB FR 7	Ref. No. 401010281	Divider FR 07-0

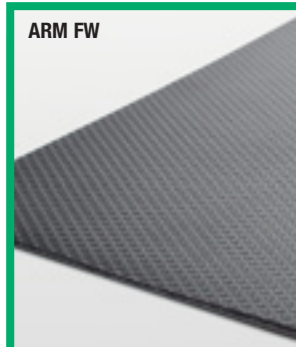

ARM FW

Knubbed mat

ARM FW 13-0	Ref. No. 651002948	Anti-rattle mat 13-0
ARM FW 14-0	Ref. No. 651002955	Anti-rattle mat 14-0
ARM FW 15-0	Ref. No. 651002964	Anti-rattle mat 15-0
ARM FW 23-0	Ref. No. 651002950	Anti-rattle mat 23-0
ARM FW 24-0	Ref. No. 651002959	Anti-rattle mat 24-0
ARM FW 25-0	Ref. No. 651002965	Anti-rattle mat 25-0
ARM FW 33-0	Ref. No. 651002951	Anti-rattle mat 33-0
ARM FW 34-0	Ref. No. 651002960	Anti-rattle mat 34-0
ARM FW 35-0	Ref. No. 651002966	Anti-rattle mat 35-0
ARM FW 43-0	Ref. No. 651002952	Anti-rattle mat 43-0
ARM FW 44-0	Ref. No. 651002961	Anti-rattle mat 43-0
ARM FW 45-0	Ref. No. 651002967	Anti-rattle mat 45-0
ARM FW 53-0	Ref. No. 651002953	Anti-rattle mat 53-0
ARM FW 54-0	Ref. No. 651002962	Anti-rattle mat 54-0
ARM FW 55-0	Ref. No. 651002968	Anti-rattle mat 55-0
ARM FW 63-0	Ref. No. 651002954	Anti-rattle mat 63-0
ARM FW 64-0	Ref. No. 651002963	Anti-rattle mat 64-0
ARM FW 65-0	Ref. No. 651002969	Anti-rattle mat 65-0
ARM FW 17-0	Ref. No. 651005507	Anti-rattle mat 17-0
ARM FW 27-0	Ref. No. 651005146	Anti-rattle mat 27-0
ARM FW 37-0	Ref. No. 651005148	Anti-rattle mat 37-0
ARM FW 47-0	Ref. No. 651005149	Anti-rattle mat 47-0
ARMT FW 44-0	Ref. No. 651015820	Anti rattle mat „Top“ 44-0
ARMT FW 45-0	Ref. No. 651015821	Anti rattle mat „Top“ 45-0

Plastic recyclate mat

Sortimo Globelyst Supplement parts

Dividers and anti rattle mats for drawers

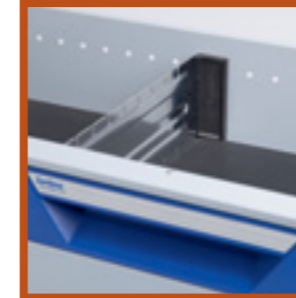

Drawer divider holders

connects the divider and the drawer

SBLTB 00-6	Ref. No. 411002991	Drawer divider holder 63
SBLTB 00-8	Ref. No. 411002992	Drawer divider holder 95

connects dividers to the slotted dividers

ATB 9	Ref. No. 491003938	Adapter for divider
DATB 9	Ref. No. 491003307	Double adapter for divider



Slotted dividers/dividers

Divides the drawer in the depth

SB 04-6 310	Ref. No. 411003659	Slotted divider 62 x 310 mm
SB 04-8 310	Ref. No. 411003660	Slotted divider 93 x 310 mm
SB 05-6 414	Ref. No. 411003695	Slotted divider 62 x 414 mm
SB 05-8 414	Ref. No. 411003696	Slotted divider 93 x 414 mm
SB 07-6 622	Ref. No. 411003697	Slotted divider 62 x 622 mm
SB 07-8 622	Ref. No. 411003698	Slotted divider 93 x 622 mm

Divides the drawer crossways

TB 20-6 154	Ref. No. 411003651	Cross divider 62 x 154,5 mm
TB 20-6 235	Ref. No. 411003652	Cross divider 62 x 235,5 mm
TB 20-8 154	Ref. No. 411003655	Cross divider 93 x 154,5 mm
TB 20-8 235	Ref. No. 411003656	Cross divider 93 x 235,5 mm
TB 30-6 424	Ref. No. 411003653	Cross divider 62 x 424,5 mm
TB 30-8 424	Ref. No. 411003657	Cross divider 93 x 424,5 mm
TB 40-6 559	Ref. No. 411003654	Cross divider 62 x 559,5 mm
TB 40-8 559	Ref. No. 411003658	Cross divider 93 x 559,5 mm



Small components insert for drawers

SBL TE 10	Ref. No. 411016008	Small components insert for drawers 24
------------------	--------------------	--



Anti-rattle mats for drawers

ARM S 24-0	Ref. No. 651003661	Anti-rattle mat drawer 24-0
ARM S 34-0	Ref. No. 651003662	Anti-rattle mat drawer 34-0
ARM S 44-0	Ref. No. 651003663	Anti-rattle mat drawer 44-0
ARM S 25-0	Ref. No. 651003664	Anti-rattle mat drawer 25-0
ARM S 35-0	Ref. No. 651003665	Anti-rattle mat drawer 35-0
ARM S 45-0	Ref. No. 651003666	Anti-rattle mat drawer 45-0
ARM S 27-0	Ref. No. 651005159	Anti-rattle mat drawer 27-0
ARM S 37-0	Ref. No. 651005160	Anti-rattle mat drawer 37-0
ARM S 47-0	Ref. No. 651005161	Anti-rattle mat drawer 47-0
ARM TS 44-0	Ref. No. 651015817	Anti rattle mat „Top“ for drawer 44-0
ARM TS 45-0	Ref. No. 651015819	Anti rattle mat „Top“ for drawer 45-0

Sortimo Globelyst Supplement parts



S-BOXXes



SB 03-8	Ref. No. 41003205	S-BOXX 03-8	Dim. (LxWxH): 150x243x136 mm
SB 04-9	Ref. No. 41003206	S-BOXX 04-9	Dim. (LxWxH): 150x347x153 mm
TWSB 03/04	Ref. No. 41003723	Divider S-BOXX 03-04	
SB 05-11	Ref. No. 41003207	S-BOXX 05-11	Dim. (LxWxH): 150x417x187 mm
TWSB 05-11	Ref. No. 41003725	Divider S-BOXX 05-11	

Wide S-BOXXes



SBB 03-9	Ref. No. 41012350	S-BOXX 03-8	Dim. (LxWxH): 300x243x136 mm
SBB 04-9	Ref. No. 41012351	S-BOXX 04-9	Dim. (LxWxH): 300x347x153 mm
TWSBB 03/04	Ref. No. 41012353	Divider S-BOXX 03-04	
SBB 05-11	Ref. No. 41012352	S-BOXX 05-11	Dim. (LxWxH): 300x417x187 mm
TWSBB 05-11	Ref. No. 41012354	Divider S-BOXX 05-11	

E-BOXXes with and without lid



E-BOXX 300x200x148	Ref. No. 37234070	Dimensions (LxWxH): 300 x 200 x 148 mm
E-BOXX 400x300x148	Ref. No. 37234049	Dimensions (LxWxH): 300 x 400 x 147 mm
E-BOXX 400x300x270	Ref. No. 37234063	Dimensions (LxWxH): 300 x 400 x 270 mm
E-BOXX 600x400x148	Ref. No. 37234032	Dimensions (LxWxH): 600 x 400 x 148 mm
E-BOXX 600x400x270	Ref. No. 37234056	Dimensions (LxWxH): 600 x 400 x 270 mm
E-BOXX Lid 400x300	Ref. No. 37234148	Dimensions (LxWxH): 400 x 300 x 25 mm
E-BOXX Lid 600x400	Ref. No. 37234155	Dimensions (LxWxH): 600 x 400 x 25 mm
E-BOXX Seat holder	Ref. No. 371007909	Dimensions (LxW): 600 x 400 mm

Case clamp



Easy-to-use, variable clamp fixing for cases or containers. It is mounted under the in-vehicle equipment.

Available in all system widths. Please ask individually.

Long components trays



Ideal for transporting long components inside the vehicle.

LGW	Ref. No. 181003900	extendable from 1600 to 3100 x 271 x 100 mm
LGW1	Ref. No. 181003899	extendable from 1600 to 3100 x 375 x 100 mm
KLGW	Ref. No. 181003901	console for long component tray

Aluminium long components trays



ALGW 84-7	Ref. No. 181011489	Aluminium long components tray Dimensions (LxWxH) 2017 x 335 x 115 mm
ALGWD 84-7	Ref. No. 181011490	lid for aluminium long components tray
ALGWK 04-7	Ref. No. 181012273	console for aluminium long components tray
ALGWTB 84-7	Ref. No. 181011492	divider for aluminium long components tray

Corner shelf tray



EFW T4-T3 L	Ref. No. 401012367	Corner shelf tray T4-T3 left side Dimensions (LxWxH): 608 x 503 x 119 mm Weight: 4,7 kg
EFW T4-T3 R	Ref. No. 401012386	Corner shelf tray T4-T3 right side Dimensions (LxWxH): 503 x 608 x 119 mm Weight: 4,7 kg
EFW T4-T4	Ref. No. 401012366	Corner shelf tray T4-T4 Dimensions (LxWxH): 608 x 608 x 119 mm Weight: 5,0 kg

Floor lashing tracks



The floor lashing tracks are screwed to the in-vehicle equipment and the floor.

BVZS 20-2	Ref. No. 441011392	Floor lashing track 20-2
BVZS 30-2	Ref. No. 441011393	Floor lashing track 30-2
BVZS 40-2	Ref. No. 441011394	Floor lashing track 40-2
BVZS 50-2	Ref. No. 441011395	Floor lashing track 50-2
BVZS 60-2	Ref. No. 441011396	Floor lashing track 60-2

All prices plus VAT and shipping. Our delivery and payment terms are applicable. See: www.sortimo.com/GTCT. Prices are only applicable for orders within Germany.



The Sortimo tailgate tent

**For land surveyors,
utility companies and
other trades**

To set up the tailgate tent will take no more than 3 minutes.

Attention:
Only to be used on vehicles with a tailgate.

- Available for:**
- ▶ Mercedes-Benz Vito
 - ▶ Nissan Primastar, Opel Vivaro, Renault Trafic
 - ▶ VW T5



Sortimo Workbenches



Folding slide out workbench

Workbench foldable, without vice.
Available for all system widths and depths.

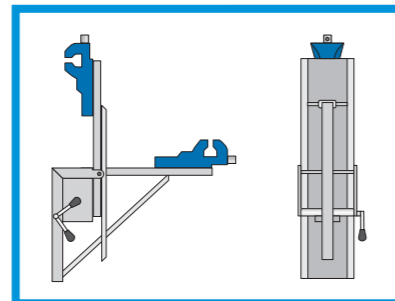

Workbench hinged

WB KL Ref. No. 221003897
Plate dim. (WxDxH): 195 x 583 x 30 mm
Workbench foldable, without vice.
Height from floor to bench 515 mm.

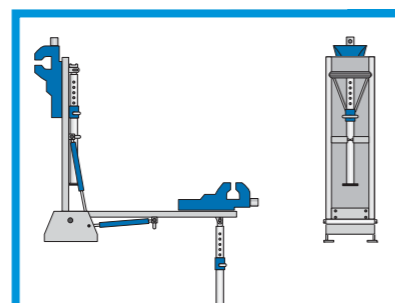

Short heavy workbench

WB SKLKF Ref. No. 22241009
Plate dim. (WxDxH): 280 x 1000 x 36 mm
Heavy workbench, foldable with short foot, without vice, Height from floor to bench 123 mm.

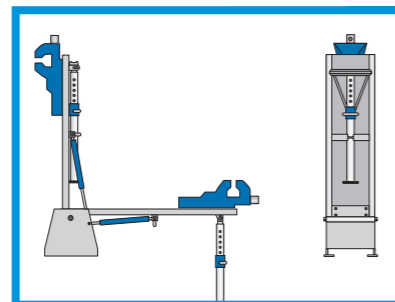

Heavy workbench

WB SKL Ref. No. 22241016
Plate dim. (WxDxH): 280 x 1000 x 36 mm
Heavy workbench, foldable with high foot, without vice, Height from floor to bench 265 mm.



Work tent for the tailgate

- | | | |
|-----------------|--------------------|--------------------|
| ZAH RETR | Ref. No. 801012294 | Renault Trafic |
| ZAH MBVI | Ref. No. 801012295 | Mercedes-Benz Vito |
| ZAH VWT5 | Ref. No. 801012293 | Volkswagen T5 |

The convenient rear tent makes work independent of the weather. It is quickly and easily mounted to the tailgate, and provides additional protection. Fasten with four loops on the ground.



Aluminium folding table

ZKLAPP Ref. No. 801009387
Dimensions (LxW): 640 x 500 mm
Carrying capacity 25 kg



Folding bracket

ZKK Ref. No. 801013383
Dimensions (LxWxH): 300 x 25 x 30 mm
Carrying capacity up to 200 kg
2 Pieces

Without plate

All prices plus VAT and shipping.
Our delivery and payment terms are applicable. See: www.sortimo.com/GTCT
Prices are only applicable for orders within Germany.





Warning- Dangerous goods!

When transporting gas bottles or refrigerants, caution is necessary!

Time and again careless securing of dangerous goods leads to serious accidents. By observing the guidelines as determined by the law and responsible handling of dangerous loads you can avoid the serious consequences of an accident.

Sortimo offers the accessories you need to safely transport dangerous loads.



Of course we also have a warning triangle as part of our accessory programme. What we hope is that you will never have to use it.

Sortimo

The ventilation system

Ventilation systems for the safe transport of gases in a utility vehicle.

The law demands that when transporting gas bottles a ventilation system be installed.

Sortimo offers a ventilation system which can be used for up ventilation or down ventilation. When tested in wind tunnel conditions the results were superb, and exceeded the legal requirements substantially.

Down ventilation:

Over pressure is achieved by setting the roof vent. This means heavy gases such as propane are exhausted via the floor and the side vents.

Up ventilation:

Under pressure is created and fresh air is drawn in through the floor and side vents and is exhausted through the roof vent taking light gases like acetylene with it.

For information on the safe storage of gas bottles see page 64.

Regulations when transporting hazardous material:

- ▶ Please carry a 2 kg fire extinguisher inside your vehicle.
- ▶ Please note that according to legislation certain materials may not be transported together (material classes 1, 4.1 and 5.2)
- ▶ Please make sure to use only suitable packaging.

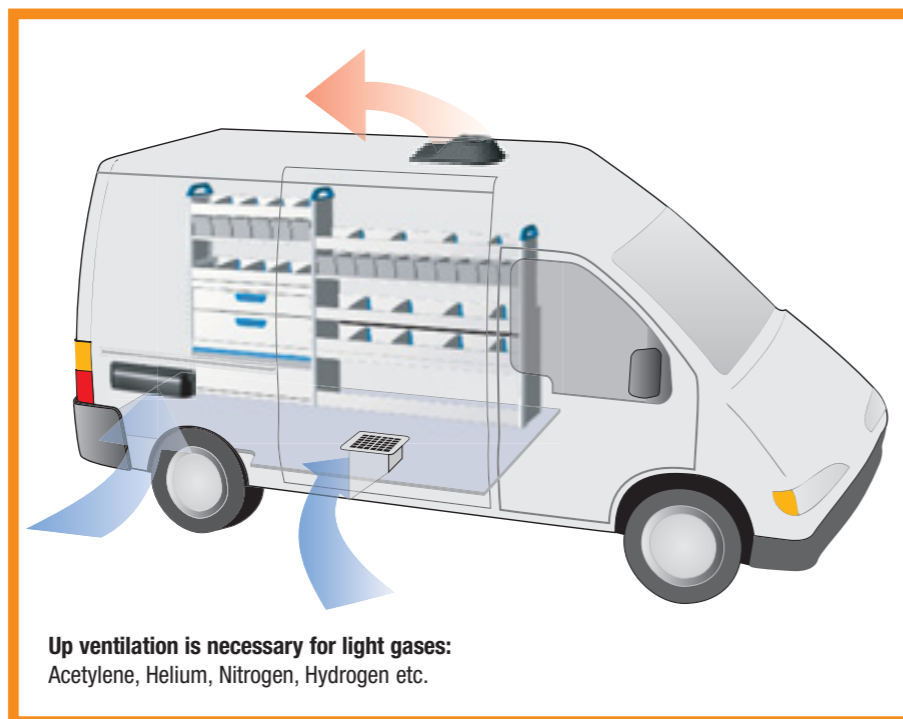
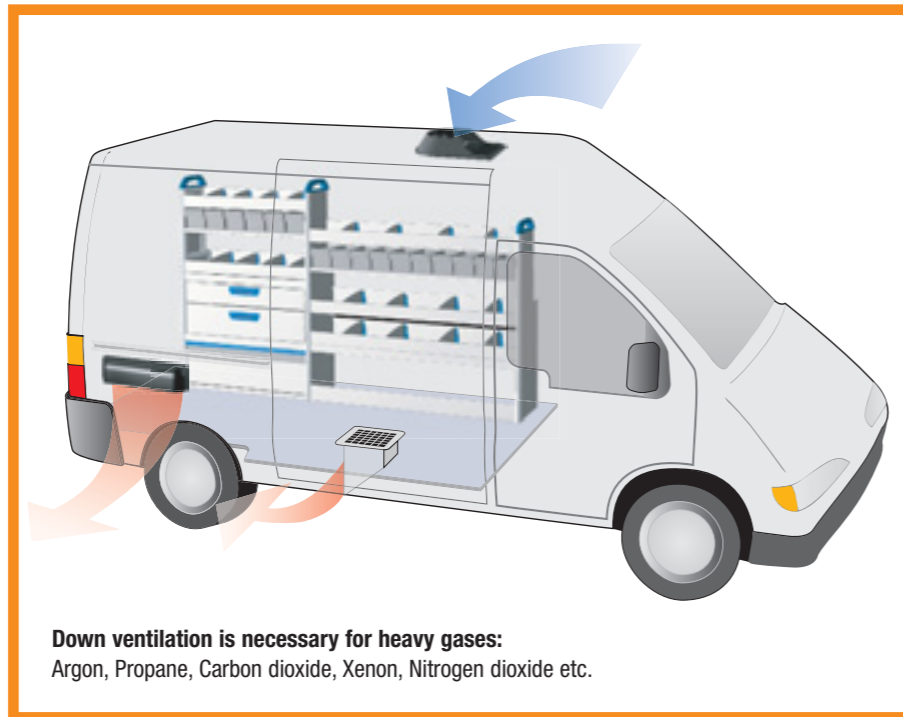

Roof ventilator*

DL	Ref. No. 80721099	DLA T5	Ref. No. 801001334
Dimensions (LxWxH): 194 x 255 x 46 mm		Dimensions (LxW): 438 x 250 mm	
Dual purpose inlet and outlet functions. Made of UV resistant sturdy black plastic which can be painted. Wind tunnel tested.		Roof ventilation adapter VW T5	
		Obligatory when fitting roof ventilator to a VW T5	

Side ventilator*

SEL	Ref. No. 80721082
Dimensions (LxW): 445 x 150 mm	
Made of UV resistant sturdy black plastic which can be painted.	
SEL W white	Ref. No. 801015695
Not shown	

Louvred panel vent 3*

ZLB 3	Ref. No. 80721037
Dimensions (LxW): 230 x 115 mm	
ZLB 4	Ref. No. 80713445
Dimensions (LxW): 285 x 175 mm	
Stainless steel plus fixings	

Floor ventilator*

BL	Ref. No. 27232502
Dimensions (WxLxH): 150 x 150 x 150 mm	
Floor ventilator with a ventilation area of approx. 100 cm ² . Galvanised finish.	

Sortimo®

Practical Tips:

According to the Transport of Dangerous Goods Regulations and the bulletin DVS 0211, vehicles transporting gases in pressurized containers should have ventilation in the vehicle. One opening should be in the front of the roof, the other on the rear bottom of the vehicle.

* The ventilation systems from Sortimo comply with legislation.

The safe transport of gas bottles

Securing of gas and refrigerant bottles made easy

Using the professional in-vehicle Sortimo Globelyst, you will have no problems transporting gas and refrigerant bottles.

The Sortimo ratchet strap lets you safely secure gas bottles to your in-vehicle equipment.

The refrigerant shelf from the Globelyst system lets you secure up to 6 bottles.



see BL 43-0/1 page 42

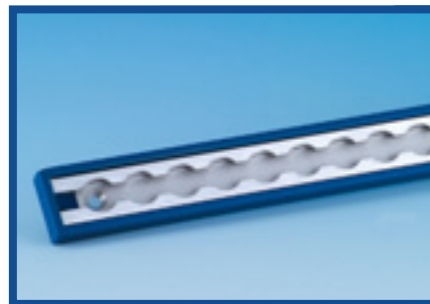

Lashing channel for gas bottles

VZS 03-3
Ref. No. 801015704

Dimensions (WxLxH):
451 x 43 x 15 mm
Weight: 0,24 kg

Lashing channel 03-3

VZS 04-3
Ref. No. 801003318

Dimensions (WxLxH):
355 x 43 x 15 mm
Weight: 0,28 kg

Lashing channel 04-3

VZS 05-3
Ref. No. 801003319

Dimensions (WxLxH):
459 x 43 x 15 mm
Weight: 0,35 kg

Lashing channel 05-3



Ratchet strap

GGFH VZS Ref. No. 491004289

Weight: 0,47 kg
Ratchet strap with gas bottle fitting

Lashing channel not included in delivery

GGKH Ref. No. 801008442

Weight: 0,52 kg
Ratchet strap w. fitting for refrigerant bottle

Lashing channel not included in delivery

All prices plus VAT and shipping. Our delivery and payment terms are applicable.
See: www.sortimo.com/GTCT. Prices are only applicable for orders within Germany.

With Sortimo you are always on top

Perfection for the top of your vehicle with the Sortimo roof rack system

The well thought out roof rack system from Sortimo is characterized above all by its flexibility. Depending on the requirements, you decide yourself if a basic roof rack solution is enough for you or if your job demands more.

Naturally, you can add to your basic roof rack system at any time. The Sortimo TopSystem can be optionally used with a roof box which is very useful for small vehicles where maximizing space is important.



Sortimo's TopSystem – more than just a roof rack.



The profile supports can be placed in a variety of positions

The profile supports secure the load to the side wall. They can be shortened and installed wherever you need them. Profile supports are securely joined with the cross supports by means of stainless steel T adapters.



The transport tube

The perfect addition to the TopSystem. The transport tube is ideal for securely storing long goods and keeping them dry. The tube has an integrated retrieval device for short pieces. The lid can be closed.

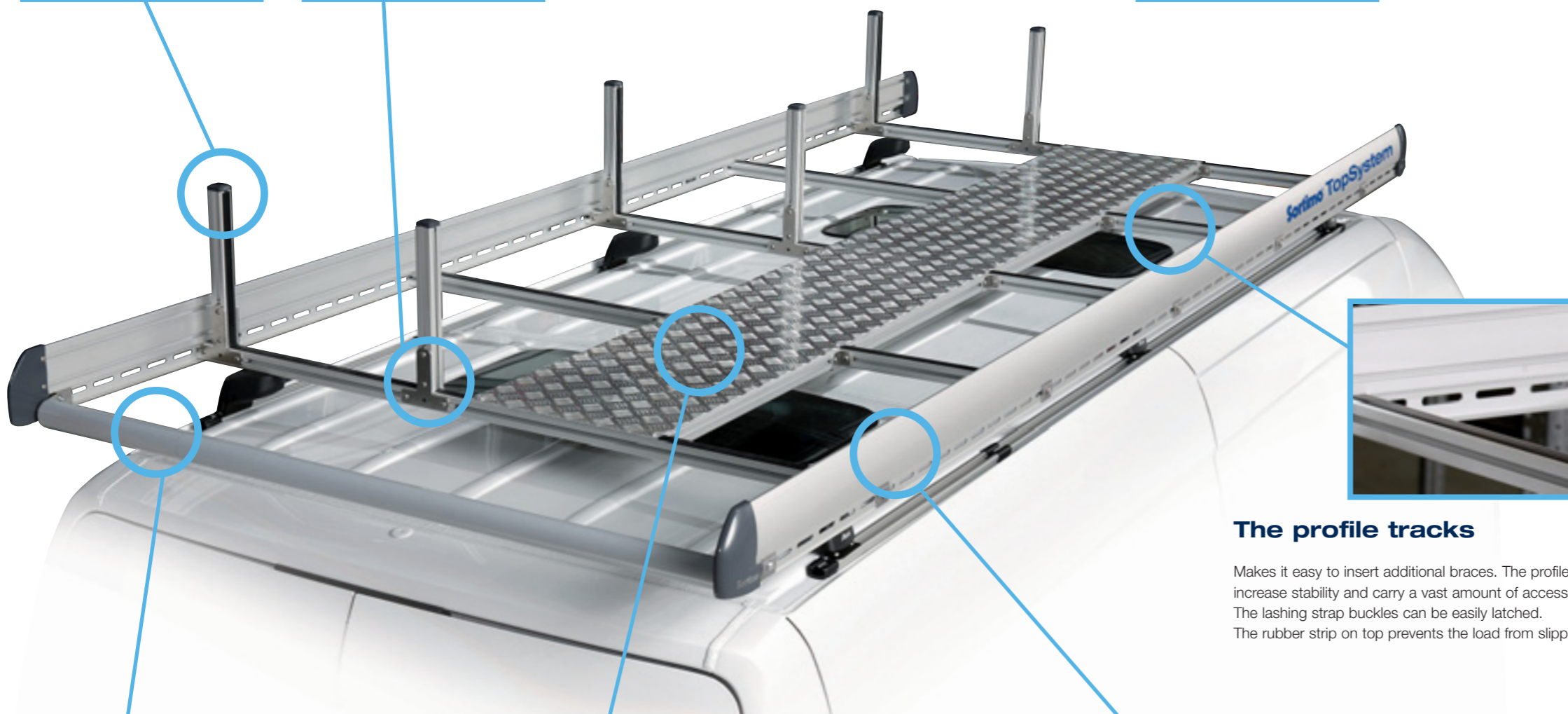

The profile tracks

Makes it easy to insert additional braces. The profile tracks increase stability and carry a vast amount of accessories. The lashing strap buckles can be easily latched. The rubber strip on top prevents the load from slipping.



The loading roller

The ideal helper for heavy or large transportation goods. Your loading material can be comfortably rolled onto the roof. The loading roller is available in the following widths: 500, 1250, 1350, 1450, 1550, 1650 and 1750 mm.



The roof rack Foot bridge

Made of non-slip aluminium chequered sheet plates it is extremely slip proof. You can now walk on your TopSystem and guarantee secure lashing of your load. Additional TopSystem foot bridges can be easily installed.



The side rail

The aluminium side rail increases stability and accepts as many cross supports as you need. Your company logo can be attached to the side rail. You can transport a ladder from job to job without damaging your vehicle.



The roof box

With a maximum carrying capacity of 75kg and 550 l. of additional loading space, it is ideal for small vehicles. The roof box can be opened from both sides and is lockable.

Your benefits:

- ▶ From the market leader for professional load safety – everything from one source with Sortimo
- ▶ Available for most all vehicle models
- ▶ Successfully crash tested in accordance with DIN 75302
- ▶ Maximum payload at minimum total weight
- ▶ Enhances your loading area
- ▶ No corrosion – the basic structure of the Sortimo TopSystem is made of anodised aluminium. All connecting elements are made of stainless steel
- ▶ Lightweight but amazingly sturdy
- ▶ This simple load safety feature with patented quick release anchor offers great flexibility
- ▶ Subsequent upgrading of the roof rack is made possible by the modularly structured system
- ▶ The roof rack system can be simply transferred from one vehicle to another
- ▶ 3 year guarantee

Sortimo®

The TopSystem grows with your requirements

Basic



- Basic solution:**
- ▶ 4 feet with 2 cross supports

Standard



- Standard solution:**
- ▶ 6 feet with 3 cross supports
 - ▶ 2 aluminium side rails
 - ▶ 1 loading roller
 - ▶ 3 lashing straps with patented quick release anchors
 - ▶ 4 profile supports for variable installation

Premium



- Premium solution:**
- ▶ 6 feet with 3 cross supports
 - ▶ 2 aluminium side rails
 - ▶ 1 transport tube
 - ▶ 4 profile supports for variable installation
 - ▶ 1 lashing strap with patented quick release anchors
 - ▶ 1 roof rack footbridge
 - ▶ 1 loading roller
 - ▶ 2 orange warning beacons



The Sortimo ladder lift

When it comes to heavy loads or ladders to be safely stowed and attached on the roof of a delivery van, then Sortimo's ladder lift is ideal. All single- and multi-ladders can be easily handled from the ground.

Operation of the ladder lift:

- ▶ After releasing the locking bolt the ladder can be pulled backwards with a hook and tilted downwards.
- ▶ The weight of the ladder is still mostly on the ladder lift.
- ▶ At the lowest point the ladder can be taken out easily.
- ▶ In reverse order, the ladder is put on the ladder lift and pushed upward.
- ▶ Lock the safety bolt into position again and you are set to go.

Please ask whether your vehicle is suitable for a ladder lift.



The Sortimo ladder-lift makes it easy to load and unload ladders.

DTLL Ladder lift

DTLL Ref. No. 81715135

- ▶ Comfortable transport of ladders, easy loading and unloading of ladders
- ▶ No need to climb on the roof
- ▶ Carrying capacity 30 kg.
- ▶ Ladder sizes Width 260-500 mm, Length 2260-2870mm (Foot of ladder to top rung)
- ▶ Assembly on at least two roof cross supports

Dimensions (WxHxD)
620 x 100 x 3030 mm

The load is easy to secure and lash down



Put the quick release anchor tilted on the cross support ...



press the spring down and turn the hook ...

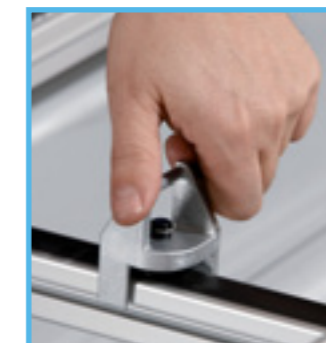

until the hooks lock in the hollow profile of the cross support, ...



now pull the ratchet strap through the eye and lash securely.



Safe lashing on the roof used to be a problem.

Using Sortimo's new patented quick release anchor it is easy to secure the load.

The quick release anchor can be easily clicked into the cross supports wherever needed. Then the strap can be fed through the eye and secured with the ratchet lock. You can choose between individual quick release anchors and a ratchet strap with permanently attached quick release anchors.

All prices plus VAT and shipping. Our delivery and payment terms are applicable. See: www.sortimo.com/GTCT. Prices are only applicable for orders within Germany.

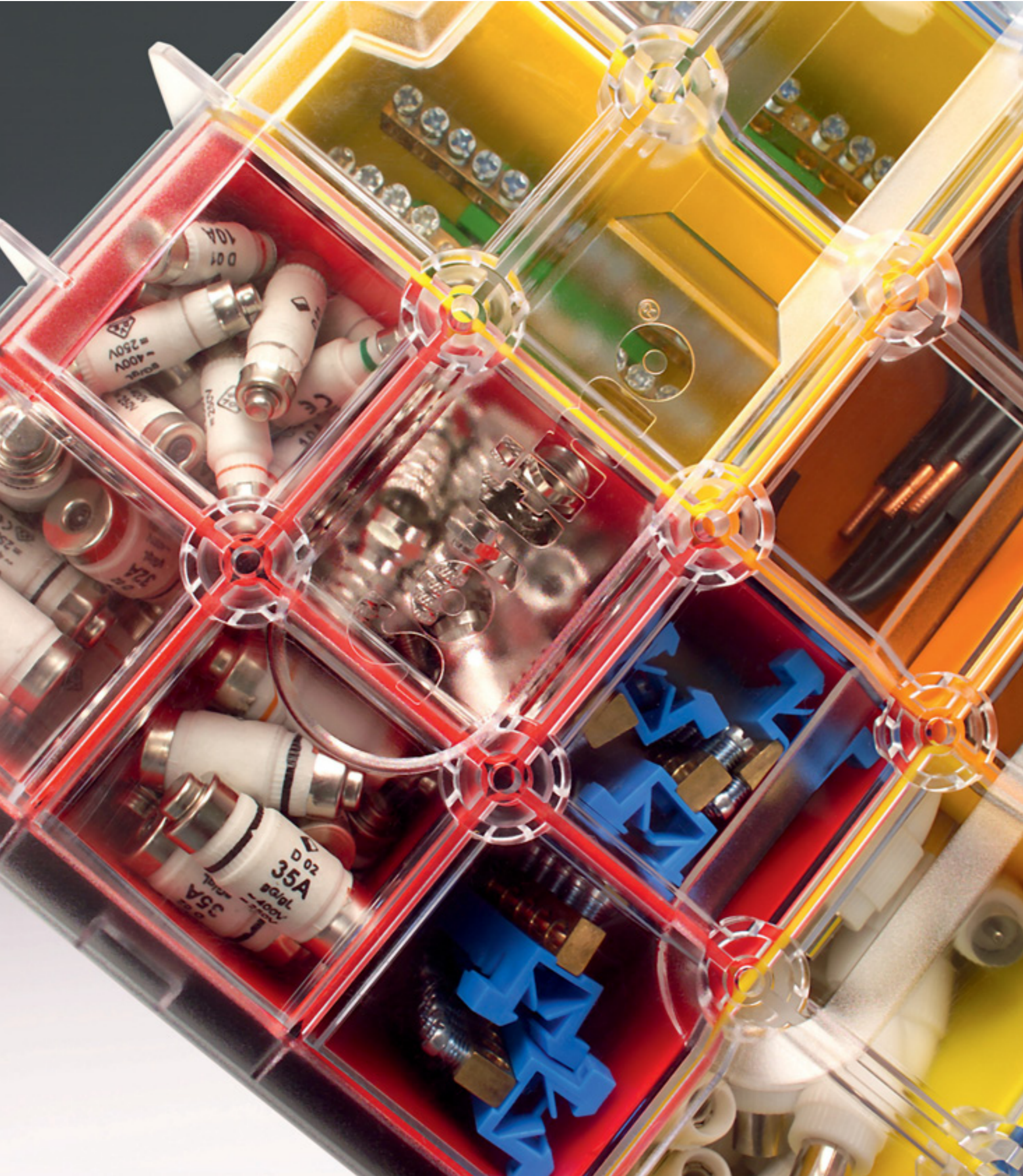

Organisation becomes mobile with Sortimo

The mobile product range ensures organisation and safety.

The classic Sortimo metal case was the basis for a variety of transport containers for the safe transport of tools, small parts, spare parts or screws.

Using the transparent T-BOXX and the innovative L-BOXX means nothing stands in the way of safe transport.

The perfect integration of the Sortimo in-vehicle equipment makes the mobile product line an integral part of a load safety system.



The legendary Sortimo metal case



The Case – Sortimo’s legendary original. It is both durable and versatile. Sortimo has developed the complete building block Globelyst System around this classic case.

The Sortimo service case product range is well – equipped to meet all your requirements on the job. Whether for business or for service and installation, the well organized system for tools, materials and small parts makes it easier to get the job done. The service case trays can be completely pulled out. The locking mechanism can be comfortably operated with one hand. The lid has a large 120° hinge bracket. The tough powder coated finish keeps the case in use year after year.

Sortimo Small Parts and Twin Level Component Cases



KM 320
Ref. No. 5228000
 Dim. (WxDxH): 440 x 330 x 66 mm
 Weight: 2,6 kg
 Without Sortimo inset boxes.



KM 321 A
Ref. No. 5228017
 Dim. (WxDxH): 440 x 330 x 66 mm
 Weight: 3,5 kg
 Equipped with:
 48 x inset boxes A3, red



KM 321 B
Ref. No. 5228024
 Dim. (WxDxH): 440 x 330 x 66 mm
 Weight: 3,4 kg
 Equipped with:
 24 x inset boxes B3, yellow



KM 321 C
Ref. No. 5228031
 Dim. (WxDxH): 440 x 330 x 66 mm
 Weight: 3,5 kg
 Equipped with:
 12 x inset boxes C3, blue



KM 321 D
Ref. No. 5228048
 Dim. (WxDxH): 440 x 330 x 66 mm
 Weight: 3,5 kg
 Equipped with:
 8 x inset boxes D3, green



KM 321 E
Ref. No. 5228055
 Dim. (WxDxH): 440 x 330 x 66 mm
 Weight: 3,3 kg
 Equipped with inset boxes:
 12 x A3 red, 6 x B3 yellow,
 3 x C3 blue, 2 x D3 green



KM 322 E
Ref. No. 5228093
 Dim. (WxDxH): 440 x 330 x 66 mm
 Weight: 4,3 kg
 Lower level equipped with: each 1 x B4 yellow, C3 blue, 1 x D3 green, 18 x A4 red and 9 x B4 yellow. Upper level equipped with: 18 x A4 red, 9 x B4 yellow



KM 330
Ref. No. 5228390
 Dim. (WxDxH): 440 x 330 x 100 mm
 Weight: 3,0 kg
 Without Sortimo inset boxes.



KM 332 E
Ref. No. 5228406
 Dim. (WxDxH): 440 x 330 x 100 mm
 Weight: 4,7 kg
 Lower level equipped with: 12 x A3 red, 6 x B3 yellow, 3 x C3 blue, 2 x D3 green. Upper level equipped with: 24 x A4 red, 12 x B4 yellow



KM 332 F
Ref. No. 5228413
 Dim. (WxDxH): 440 x 330 x 100 mm
 Weight: 4,8 kg
 Lower level equipped with:
 6 x B3 yellow, 3 x C3 blue, 2 x D3 green
 Upper level equipped with: 18 x A4 red, 9 x B4 yellow



KM 340
Ref. No. 5228550
 Dim. (WxDxH): 440 x 330 x 130 mm
 Weight: 3,5 kg
 Without Sortimo inset boxes.



KM 342 E
Ref. No. 5228567
 Dim. (WxDxH): 440 x 330 x 130 mm
 Weight: 6,2 kg
 Lower level equipped with:
 12 x A3 red, 6 x B3 yellow, 3 x C3 blue,
 2 x D3 green
 Upper level equipped with:
 12 x A3 red, 6 x B3 yellow, 3 x C3 blue,
 2 x D3 green



DM 332 E
Ref. No. 5228475
 Dim. (WxDxH): 440 x 330 x 100 mm
 Weight: 4,6 kg
 Lower level equipped with: divider kit
 Upper level equipped with: inset boxes
 24 x A4 red and 12 x B4 yellow



DM 342 E
Ref. No. 5228611
 Dim. (WxDxH): 440 x 330 x 130 mm
 Weight: 5,4 kg
 Lower level equipped with: divider kit
 Upper level equipped with: inset boxes
 12 x A3 red and 6 x B3 yellow, 3 x C3 blue und 2 x D3 green



DM 352 E
Ref. No. 5228765
 Dim. (WxDxH): 440 x 330 x 170 mm
 Weight: 6,0 kg
 Lower level equipped with: divider kit
 Upper level equipped with: 12 x A3 red and 6 x B3 yellow, 3 x C3 blue and 2 x D3 green



KM 120
Ref. No. 5229038
 Dim. (WxDxH): 330 x 220 x 66 mm
 Weight: 1,6 kg
 Without Sortimo inset boxes
 The 120 does not fit into the Globelyst system.



KM 121 E
Ref. No. 5229045
 Dim. (WxDxH): 330 x 220 x 66 mm
 Weight: 2,0 kg
 Equipped with: inset boxes 8 x A3 red, 4 x B3 yellow, 2 x C3 blue



KM 122 E
Ref. No. 5229113
 Dim. (WxDxH): 330 x 220 x 66 mm
 Weight: 2,0 kg
 Lower level equipped with: 10 x A4 red, 5 x B4 yellow, 1 x C3 blue, 2 x B4 red, 1 x B3 yellow. Upper level equipped with: 8 x A4 red, 4 x B4 yellow

All prices plus VAT and shipping. Our delivery and payment terms are applicable. See: www.sortimo.com/GTCT. Prices are only applicable for orders within Germany.



Sortimo Tool cases and Service cases



WM 320
Ref. No. 5228109
 Dim. (WxDxH): 440 x 330 x 66 mm
 Weight: 2,9 kg
 Tool case
 No divider set



WM 321
Ref. No. 5228116
 Dim. (WxDxH): 440 x 330 x 66 mm
 Weight: 3,0 kg
 Tool case
 Incl. divider set



WM 330
Ref. No. 5228444
 Dim. (WxDxH): 440 x 330 x 100 mm
 Weight: 3,4 kg
 Tool case
 No divider set



WM 331
Ref. No. 5228451
 Dim. (WxDxH): 440 x 330 x 100 mm
 Weight: 3,4 kg
 Tool case
 Incl. divider set



WM 340
Ref. No. 5228581
 Dim. (WxDxH): 440 x 330 x 130 mm
 Weight: 3,8 kg
 Tool case
 No divider set



WM 341
Ref. No. 5228598
 Dim. (WxDxH): 440 x 330 x 130 mm
 Weight: 4,0 kg
 Tool case
 Incl. divider set



WM 350
Ref. No. 5228734
 Dim. (WxDxH): 440 x 330 x 170 mm
 Weight: 4,1 kg
 Tool case
 No divider set



WM 351
Ref. No. 5228741
 Dim. (WxDxH): 440 x 330 x 170 mm
 Weight: 4,7 kg
 Tool case
 Incl. divider set



MM 350
Ref. No. 5228710
 Dim. (WxDxH): 440 x 330 x 170 mm
 Weight: 3,8 kg
 Power tool case
 Not suitable for dividers



TK 40 3/5
Ref. No. 5228529
 Dim. (WxDxH): 440 x 330 x 130 mm
 Weight: 4,0 kg
 Tool and inset box case
 Equipped with: 2 leather toolboards and inset box set IB SE2



ESK 3
Ref. No. 5228543
 Weight: 0,5 kg
 Toolboard 3
 Equipped with: toolboard for TK 40 with rubber strap and tool pockets



ESK 5
Ref. No. 5228536
 Weight: 0,5 kg
 Toolboard 5
 Equipped with Sortimo toolboard for TK 40 with pockets for tools



Foam Inserts SRE
SRE
Ref. No. 5200709
 Dim. (WxDxH): 330 x 220 x 50 + 10 mm
 Pre-cut foam inserts for equipment case.



Sortimo's special cases for boiler nozzles



DK 321
Ref. No. 5228338
 Dim. (WxDxH): 440 x 330 x 66 mm
 Weight: 3,1 kg
 Sortimo nozzle case for 165 nozzles Ø 22 mm with foam insert



DK 321 F
Ref. No. 5228345
 Dim. (WxDxH): 440 x 330 x 66 mm
 Weight: 3,1 kg
 Sortimo nozzle case for 121 nozzles Ø 22 mm with foam insert and 1 x inset box G3 green



DKS
Ref. No. 5200532
 Weight: 0,175 kg
 Foam insert for 165 nozzles Ø 22 mm fits in case or drawer 24-6



DKSF
Ref. No. 5200549
 Weight: 0,175 kg
 Foam insert for 121 nozzles Ø 22 mm and 1 x inset box G3 green, fits in case or drawer 24-6

All prices plus VAT and shipping. Our delivery and payment terms are applicable. See: www.sortimo.com/GTCT. Prices are only applicable for orders within Germany.

Accessories for Sortimo cases and drawers



Divider sets for the cases

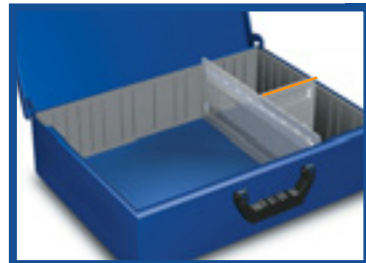

WM 320	WM 330	WM 340	WM 350
TB WM 320/145	TB WM 330/145	TB WM 340/145	TB WM 350/145
Ref. No. 5267603	Ref. No. 5267702	Ref. No. 5267801	Ref. No. 5267900
Divider	Divider	Divider	Divider



WM 320	WM 330	WM 340	WM 350
TB WM 320/262	TB WM 330/262	TB WM 340/262	TB WM 350/262
Ref. No. 5267610	Ref. No. 5267719	Ref. No. 5267818	Ref. No. 5267917
Divider	Divider	Divider	Divider



WM 320	WM 330	WM 340	WM 350
TB WM 320/309	TB WM 330/309	TB WM 340/309	TB WM 350/309
Ref. No. 5267641	Ref. No. 5267740	Ref. No. 5267849	Ref. No. 5267948
Slotted divider	Slotted divider	Slotted divider	Slotted divider

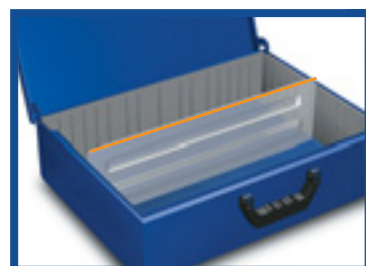

WM 320	WM 330	WM 340	WM 350
TB WM 320/415	TB WM 330/415	TB WM 340/415	TB WM 350/415
Ref. No. 5267634	Ref. No. 5267733	Ref. No. 5267832	Ref. No. 5267931
Divider	Divider	Divider	Divider



Layer trays			
BES 31 1/1	Ref. No. 5232816	inset box insert 31 mm 1/1	
BES 31 3/4	Ref. No. 5232809	inset box insert 31 mm 3/4	
BES 31 1/2	Ref. No. 5232847	inset box insert 31 mm 1/2	
BES 62 1/1	Ref. No. 5232823	inset box insert 2 mm 1/1	

Inset boxes for the cases and drawers



Inset box set IB SE3

IB SE3 Ref. No. 5240545

- ▶ 12 x A3, red
- ▶ 6 x B3, yellow
- ▶ 3 x C3, blue
- ▶ 2 x D3, green

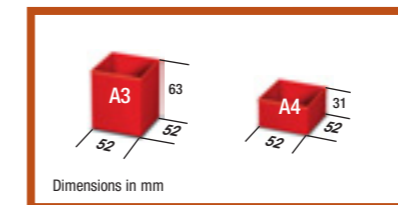

Inset boxes red A3 + A4

- | | | |
|----------|-------------------|---------------------------|
| IB SA3 | Ref. No. 5240507 | packaging unit 48 pieces |
| IB A3 VP | Ref. No. 51012355 | packaging unit 144 pieces |
| IB A4 VP | Ref. No. 5240408 | packaging unit 288 pieces |

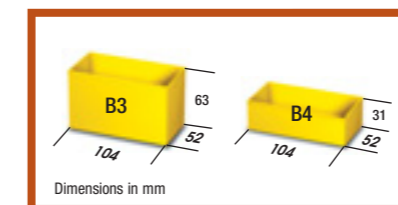

Inset boxes yellow B3 + B4

- | | | |
|----------|-------------------|---------------------------|
| IB SB3 | Ref. No. 5240514 | packaging unit 24 pieces |
| IB B3 VP | Ref. No. 51012356 | packaging unit 72 pieces |
| IB B4 VP | Ref. No. 5240422 | packaging unit 144 pieces |

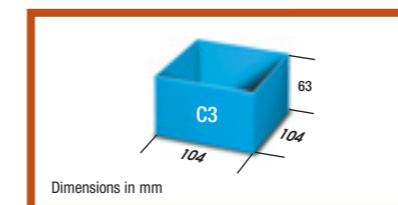

Inset boxes blue C3

- | | | |
|----------|-------------------|--------------------------|
| IB SC3 | Ref. No. 5240521 | packaging unit 12 pieces |
| IB C3 VP | Ref. No. 51012357 | packaging unit 36 pieces |

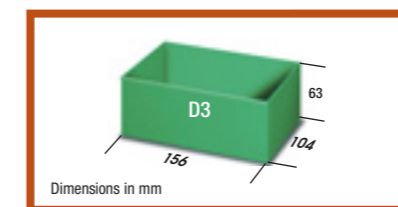

Inset boxes green D3

- | | | |
|----------|-------------------|--------------------------|
| IB SD3 | Ref. No. 5240538 | packaging unit 8 pieces |
| IB D3 VP | Ref. No. 51012358 | packaging unit 24 pieces |

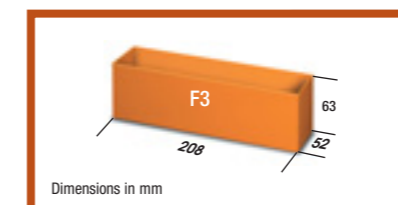

Inset boxes orange F3

- | | | |
|----------|-------------------|--------------------------|
| IB SF3 | Ref. No. 5240552 | packaging unit 12 pieces |
| IB F3 VP | Ref. No. 51012359 | packaging unit 36 pieces |

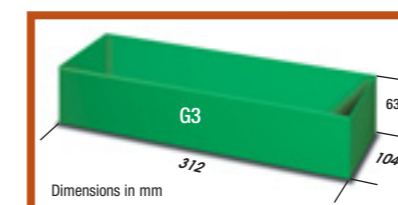

Inset boxes dark green G3

- | | | |
|----------|-------------------|--------------------------|
| IB SG3 | Ref. No. 5240569 | packaging unit 4 pieces |
| IB G3 VP | Ref. No. 51012360 | packaging unit 12 pieces |

All prices plus VAT and shipping. Our delivery and payment terms are applicable. See: www.sortimo.com/GTCT. Prices are only applicable for orders within Germany.

Sortimo tool boxes and modular inserts

The tool box combines the well known Sortimo quality case with new modular inserts. Eleven various tool insert modules for cases and drawers enable each user to pick exactly the right layout for their application, thereby retaining the Sortimo integrated in-vehicle system of order and efficiency.

The precision made branded tools are made of CV steel and guarantee quality for long service, even under the most demanding conditions.



TM 322/1

Ref. No. 5229212
 Dimensions (WxDxH):
 440 x 330 x 66 mm
 Weight: 5,0 kg
 Equipped with: TMOD 1, TMOD 2,
 TMOD 7 and boxes equipped with:
 16 x IB A4, 10 x IB B4 and
 1 divider BES 31 1/2

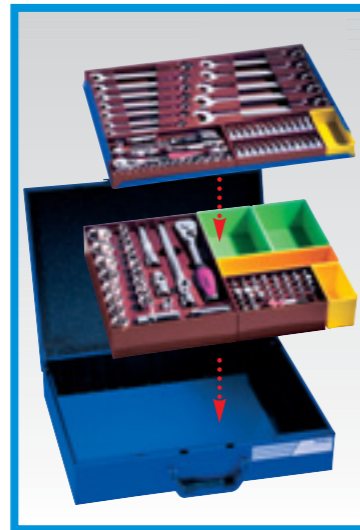

TM 332/1

Ref. No. 5229229
 Dimensions (WxDxH):
 440 x 330 x 100 mm
 Weight: 11,5 kg
 Equipped with: TMOD 1, TMOD 4,
 TMOD 5, TMOD 7, TMOD 9,
 TMOD 11
 Boxes are equipped with:
 1x IB B4, 1x IB B3, 2 x IB D3,
 1x IB F3, 1 divider BES 31 1/1

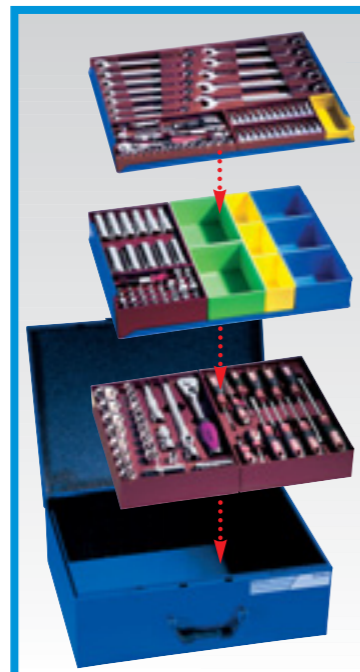

TM 353/1

Ref. No. 5229236
 Dimensions (WxDxH):
 440 x 330 x 170 mm
 Weight: 16,00 kg
 Equipped with: TMOD 1, TMOD 4,
 TMOD 5, TMOD 7, TMOD 8,
 TMOD 9, TMOD 10, TMOD 11
 Boxes are equipped with:
 1x IB B4, 3x IB B3, 3 x IB C3,
 2x IB D3 and dividers each 1 x
 BES 31 1/1 and BES 63 1/1



TMOD 1

Ref. No. 801010011
 Dim. (WxDxH): 208 x 104 x 31mm
 Weight: 0,75 kg
 1/4" socket set 22 pcs

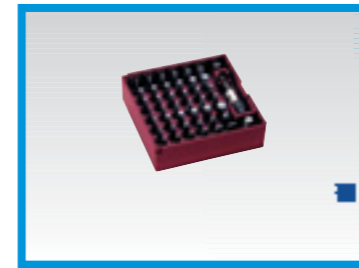

TMOD 2

Ref. No. 801010010
 Dim. (WxDxH): 104 x 104 x 31mm
 Weight: 0,36 kg
 1/4" bit set 45 pcs



TMOD 3

Ref. No. 801010009
 Dim. (WxDxH): 156 x 104 x 31mm
 Weight: 0,48 kg
 1/4" extension socket
 set 12 pcs



TMOD 4

Ref. No. 801010012
 Dim. (WxDxH): 156 x 52 x 31mm
 Weight: 0,24 kg
 1/4" bit socket set 12 pcs



TMOD 5

Ref. No. 801010008
 Dim. (WxDxH): 156 x 52 x 31mm
 Weight: 0,24 kg
 1/4" bit socket set 12 pcs



TMOD 6

Ref. No. 801010013
 Dim. (WxDxH): 416 x 208 x 31mm
 Weight: 1,83 kg
 combination ratchet spanner
 set 12 pcs



TMOD 7

Ref. No. 801010007
 Dim. (WxDxH): 312 x 208 x 63 mm
 Weight: 3,88 kg
 1/2" socket set 26 pcs



TMOD 8

Ref. No. 801010006
 Dim. (WxDxH): 208 x 156 x 63 mm
 Weight: 1,71 kg
 1/2" extension socket set
 11 pcs



TMOD 9

Ref. No. 801010005
 Dim. (WxDxH): 156 x 104 x 63 mm
 Weight: 0,63 kg
 5/16" bit set 37 pcs

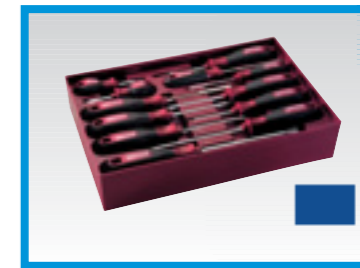

TMOD 10

Ref. No. 801010004
 Dim. (WxDxH): 312 x 208 x 63 mm
 Weight: 1,29 kg
 Screwdriver set 37 pcs



TMOD 11

Ref. No. 801010003
 Dim. (WxDxH): 416 x 208 x 31 mm
 Weight: 1,61 kg
 combination spanner set 12 pcs

All prices plus VAT and shipping. Our delivery and payment terms are applicable.
 See: www.sortimo.com/GTCT. Prices are only applicable for orders within Germany.



Sortimo T-BOXX® – The new transparent box

A great variety of application possibilities in the Sortimo Globelyst system

The new T-BOXX fits in perfectly with the Sortimo Globelyst system, otherwise it wouldn't be a Sortimo product. The T-BOXX can be installed in the system by using special rails. It fits on the aluminium floor of the M-BOXX and can be securely stored on the case trays. You can also fasten the T-BOXX to the end panel of the equipment or even to the wing doors of the vehicle, which is a new feature.



T-BOXX STB 320

STB 320
Ref. No. 51012126
 Dim. (WxDxH): 440 x 350 x 80 mm
 Weight: 1,6 kg
 Sortimo T-BOXX without inset boxes



T-BOXX STB 321 A

STB 321 A
Ref. No. 51012127
 Dim. (WxDxH): 440 x 350 x 80 mm
 Weight: 2,3 kg
 Sortimo T-BOXX A3 red



T-BOXX STB 321 B

STB 321 B
Ref. No. 51012128
 Dim. (WxDxH): 440 x 350 x 80 mm
 Weight: 2,3 kg
 Sortimo T-BOXX B3 yellow



T-BOXX STB 321 C

STB 321 C
Ref. No. 51012129
 Dim. (WxDxH): 440 x 350 x 80 mm
 Weight: 2,3 kg
 Sortimo T-BOXX C3 blue



T-BOXX STB 321 D

STB 321 D
Ref. No. 51012130
 Dim. (WxDxH): 440 x 350 x 80 mm
 Weight: 2,3 kg
 Sortimo T-BOXX D3 green



T-BOXX STB 321 E

STB 321 E
Ref. No. 51012131
 Dim. (WxDxH): 440 x 350 x 80 mm
 Weight: 2,3 kg
 Sortimo T-BOXX E3 mixed



T-BOXX STB 321 F

STB 321 F
Ref. No. 51012132
 Dim. (WxDxH): 440 x 350 x 80 mm
 Weight: 2,3 kg
 Sortimo T-BOXX F3 orange



T-BOXX STB 321 G

STB 321 G
Ref. No. 51012133
 Dim. (WxDxH): 440 x 350 x 80 mm
 Weight: 2,3 kg
 Sortimo T-BOXX G3 green



T-BOXX STB 321 H

STB 321 H
Ref. No. 51011476
 Dim. (WxDxH): 440 x 350 x 80 mm
 Weight: 2,3 kg
 Sortimo T-BOXX H Standard



Suspension adapter set

STB E
Ref. No. 51011477
 Sortimo T-BOXX adaptor set makes it possible to secure the T-BOXX to the panel of a vehicle door or in-vehicle equipment.

All prices plus VAT and shipping. Our delivery and payment terms are applicable. See: www.sortimo.com/GTCT. Prices are only applicable for orders within Germany.



A new dimension in mobility

The new Sortimo **L-BOXX**[®]

NEW

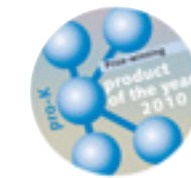

The new Sortimo L-BOXXes are the ideal solution for all mobile trade professionals and service personnel. They meet every requirement and can be integrated into the smallest mobile in-vehicle equipment unit from Sortimo.

You soon won't want to do without the L-BOXXes as your daily companion on the road. The superior ergonomics and ease of integration into the in-vehicle system from the market leader Sortimo make the L-BOXX the most unique solution on the market.

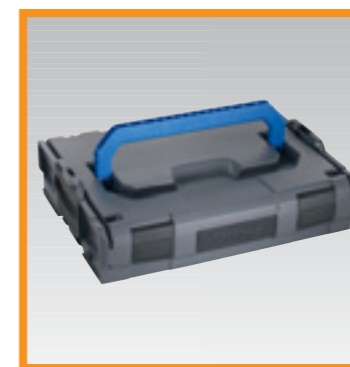

L-BOXX 102

LB 102 Ref. No. 121014674

Exterior dimensions (WxDxH):
442 x 357 x 117 mm
Interior dimensions (WxDxH):
378 x 313 x 71 mm
Weight: 2,1 kg

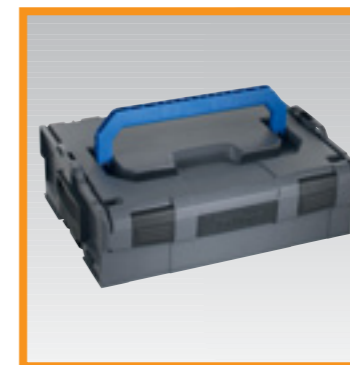

L-BOXX 136

LB 136 Ref. No. 121014675

Exterior dimensions (WxDxH):
442 x 357 x 151 mm
Interior dimensions (WxDxH):
378 x 311 x 107 mm
Weight: 2,2 kg



L-BOXX 238

LB 238 Ref. No. 121014676

Exterior dimensions (WxDxH):
442 x 357 x 252 mm
Interior dimensions (WxDxH):
378 x 306 x 209 mm
Weight: 2,8 kg



L-BOXX 374

LB 374 Ref. No. 121014677

Exterior dimensions (WxDxH):
442 x 357 x 389 mm
Interior dimensions (WxDxH):
378 x 296 x 345 mm
Weight: 3,4 kg

All prices plus VAT and shipping. Our delivery and payment terms are applicable. See: www.sortimo.com/GTCT. Prices are only applicable for orders within Germany.



Sortimo original accessories

Additional safety and organization for the Sortimo in-vehicle equipment

While working it is important to have many things quickly at hand – the long electric cable for the drill or a dry paper towel in order to quickly clean your hands.

You can equip your utility vehicle with many practical solutions using original Sortimo accessories. From document pockets to cable holders – you can always find useful original Sortimo accessories.



Sortimo original accessories

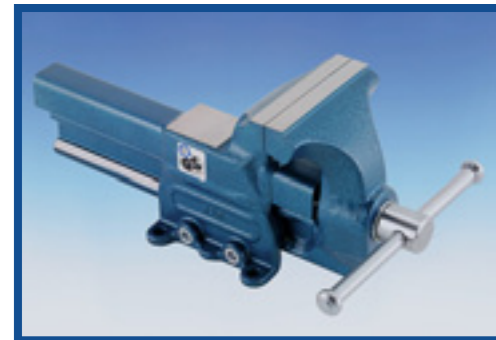

Parallel vice

ZSP 120

Ref. No. 801008322

Weight: 9,7 kg
Parallel Vice 120mm jaw, opening width 150 mm includes pipe holder. Suitable for folding and sliding work benches.

ZSP 140

Ref. No. 801008323

Weight: 16,00 kg
Parallel Vice 140mm jaw, opening width 215 mm, includes pipe holder combined with vice plate ZSD 135 is ideal for use with heavy duty bench WB SKL.



Rotating vice plates

ZSD 120

Ref. No. 801008324

Weight: 2,6 kg
Rotating vice plate for 120 mm vice.

ZSD 140

Ref. No. 801008325

Weight: 4,5 kg
Rotating vice plate for 140 mm vice.



Parallel vice

ZSP 75

Ref. No. 801010383

Weight: 1,9 kg
Rotating vice with 75mm jaw width, opening width of 44 mm.
Rotating vice to be mounted to side panel of block.

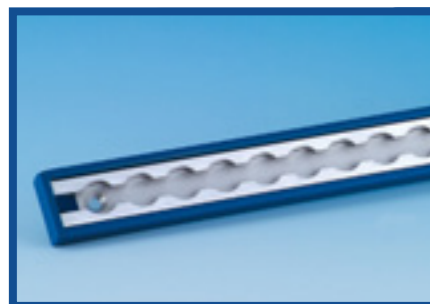

Lashing channel for gas bottles

VZS 03-3

Ref. No. 801015704

Dimensions (WxLxH):
451 x 43 x 15 mm
Weight: 0,24 kg

Lashing channel 03-3

VZS 04-3

Ref. No. 801003318

Dimensions (WxLxH):
355 x 43 x 15 mm
Weight: 0,28 kg

Lashing channel 04-3

VZS 05-3

Ref. No. 801003319

Dimensions (WxLxH):
459 x 43 x 15 mm
Weight: 0,35 kg

Lashing channel 05-3



Ratchet strap

GGFH VZS

Ref. No. 491004289

Weight: 0,47 kg
Ratchet-strap with **gas bottle fitting**

Lashing track not included in delivery.

GGKH

Ref. No. 801008442

Weight: 0,52 kg
Ratchet strap w. fitting for **coolant bottle**

Lashing track not included in delivery.



Cable holder Globelyst

ZSH

Ref. No. 801010976

Dim. (WxDxH): 204 x 113 x 201 mm

Cable holder Globelyst made of plastic with business card pocket and address field. Label set BAS see page 91.



Cable holders

ZSHK

Ref. No. 80713506

Dim. (WxDxH): 188 x 70 x 147 mm
Cable holder small

ZSHM

Ref. No. 80713599

Dim. (WxDxH): 266 x 108 x 201 mm
Cable holder medium

ZSHG

Ref. No. 80713513

Dim. (WxDxH): 348 x 144 x 257 mm
Cable holder large

The Sortimo cable holder is made of high quality powder-coated aluminium in royal blue.



All prices plus VAT and shipping. Our delivery and payment terms are applicable. See: www.sortimo.com/GTCT. Prices are only applicable for orders within Germany.



Sortimo original accessories



Gripper hook

ZUG1
Ref. No. 801012161
Gripper hook ø 20 – 30 mm

The gripper hook can be mounted on the special aluminium strip or directly to a wall or rack.

Aluminium strip

ZUG2
Ref. No. 801012162
Gripper hook ø 30 – 40 mm

The gripper hook can be mounted on the special aluminium strip or directly to a wall or rack.

ZUS
Ref. No. 801012166

Aluminium mounting strip for gripper hook. Length 90 cm



Strap bracket

ZSG 1
Ref. No. 801009976
Strap bracket ø 15 – 30 mm

Zinc plated steel with rubber strap – can be mounted on perforated panel.

ZSG 2
Ref. No. 80713858
Strap bracket ø 20 – 50 mm

Zinc plated steel with rubber strap – can be mounted on perforated panel.

Spare rubber strap

ZSG 1E
Ref. No. 491010015

ZSG 2E
Ref. No. 491010016



Pipe clamps

ZVSL 1
Ref. No. 801011062
Interior dimensions: 89 x 30 x 89 mm

For quick fastening of equipment.

ZVSL 2
Ref. No. 801011063
Interior dimensions: 59 x 30 x 63 mm

For quick fastening of equipment.

ZVSL 3
Ref. No. 801011064
Interior dimensions: 50 x 30 x 50 mm

For quick fastening of equipment.



Coat hook

ZKH1 Ref. No. 80713087

Pack of 3



4 **Overhead hook 1**

ZDH1 Ref. No. 801012834

For all long handled tools e.g. brooms and shovels.



1 **Ladder bracket**

ZLH 1 Ref. No. 801009909

Ladder bracket to secure ladders. Screwed to upright on in-vehicle equipment



Aluminium wall brackets

ZWH1 Ref. No. 801012163
Dimension (LxW): 80 x 120 mm

ZWH2 Ref. No. 801012164
Dimension (LxW): 115 x 140 mm



Aluminium wall bracket

ZWH3 Ref. No. 801012165

Dimensions (LxW): 170 x 225 mm



Cable reel holder

ZKH Ref. No. 80713094

Multi-purpose unit to secure hoses and cables to long component or shelf trays.



Tool clips

ZTC10	Ref. No. 801013272	Tool Clip 10 mm
ZTC13	Ref. No. 801013273	Tool Clip 13 mm
ZTC16	Ref. No. 801013274	Tool Clip 16 mm
ZTC19	Ref. No. 801013275	Tool Clip 19 mm
ZTC22	Ref. No. 801013276	Tool Clip 22 mm
ZTC25	Ref. No. 801013277	Tool Clip 25 mm
ZTC28	Ref. No. 801013278	Tool Clip 28 mm
ZTC32	Ref. No. 801013279	Tool Clip 32 mm
ZTC38	Ref. No. 801013280	Tool Clip 38 mm
ZTC44	Ref. No. 801013281	Tool Clip 44 mm
ZTC64	Ref. No. 801013282	Tool Clip 64 mm
ZTC76	Ref. No. 801013283	Tool Clip 76 mm
ZTC89	Ref. No. 801013284	Tool Clip 89 mm
ZTC102	Ref. No. 801013285	Tool Clip 102 mm
ZTC114	Ref. No. 801013286	Tool Clip 114 mm



2 **Threaded rod holder**

ZGSH 04-10
Ref. No. 801012176

For the safe and organized transporting of threaded rods.

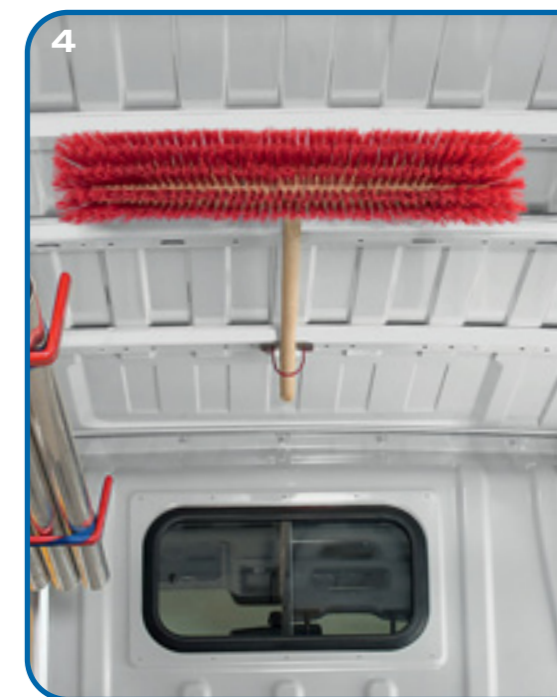

All prices plus VAT and shipping. Our delivery and payment terms are applicable. See: www.sortimo.com/GTCT. Prices are only applicable for orders within Germany.



Sortimo original accessories

Single prong hooks

	<p>WCÄ 30 Ref. No. 80714626 Dimensions (WxDxH): 27 x 60 x 47 mm Length 30 mm</p>	<p>WCÄ 60 Ref. No. 80714633 Dimensions (WxDxH): 27 x 60 x 79 mm Length 60 mm</p>	<p>WCÄ 90 Ref. No. 80714640 Dimensions (WxDxH): 27 x 60 x 107 mm Length 90 mm</p>
---	---	---	--

Single prong hooks

	<p>WCS 25 Ref. No. 80714671 Dimensions (WxDxH): 27 x 60 x 47 mm Length 25 mm</p>	<p>WCS 50 Ref. No. 80714688 Dimensions (WxDxH): 27 x 60 x 71 mm Length 50 mm</p>	<p>WCS 75 Ref. No. 80714695 Dimensions (WxDxH): 27 x 60 x 96 mm Length 70 mm</p>
---	---	---	---

Spring clip

	<p>WCK 12 Ref. No. 80714749 Spring clip Ø 12 mm</p>	<p>WCK 18 Ref. No. 80714756 Spring clip Ø 18 mm</p>	<p>WCK 24 Ref. No. 80714763 Spring clip Ø 24 mm</p>
---	--	--	--

Double prong hooks

	<p>WCÄD 30 Ref. No. 80714657 Dimensions (WxDxH): 27 x 60 x 47 mm Length of hook 30 mm</p>	<p>WCÄD 60 Ref. No. 80714664 Dimensions (WxDxH): 27 x 60 x 79 mm Length of hook 60 mm</p>
---	--	--

Wide hook double

	<p>WCSD 40 Ref. No. 80714701 Dimensions (WxDxH): 44 x 61 x 70 mm Length of hook 40 mm</p>	<p>WCSD 50 Ref. No. 80714718 Dimensions (WxDxH): 50 x 61 x 79 mm Length of hook 50 mm</p>
---	--	--

Pliers holders

	<p>WCZ 17 Ref. No. 80714725 Dimensions (WxDxH): 45 x 60 x 53 mm Length of hook 17 mm</p>	<p>WCZ 20 Ref. No. 80714732 Dimensions (WxDxH): 50 x 60 x 79 mm Length of hook 20 mm</p>
---	---	---

Pipe/tube hook

	<p>WCH Ref. No. 80714770 Dimensions (WxDxH): 27 x 60 x 93 mm Pipe/tube hook Ø 12 mm</p>
---	--



Clamping strip for tools

	<p>ZWKL Ref. No. 801012160 Dimensions (WxDxH): 340 x 30 x 45 mm Prevents your tools falling down during driving</p>
---	--

18 piece hook assortment

	<p>WCSK 18 Ref. No. 80 714831 Incl: 1x WCÄ 30, 1x WCÄ 60, 1x WCÄ 90, 1x WCÄD 30, 1x WCÄD 60, 2x WCS 25, 2x WCS 50, 1x WCS 75, 1x WCSD 30, 1x WCSD 50, 1x WCZ 17, 1x WCZ 20, 1x WCK 12, 1x WCK 18, 1x WCK 24, 1x WCH</p>	<p>28 piece hook assortment</p> <p>WCSK 28 Ref. No. 80 714848 Incl: 1x WCÄ 30, 1x WCÄ 60, 1x WCÄ 90, 1x WCÄD 30, 1x WCÄD 60, 2x WCS 25, 2x WCS 50, 1x WCS 75, 2x WCSD 30, 2x WCSD 50, 2x WCZ 17, 2x WCZ 20, 2x WCK 12, 2x WCK 18, 2x WCK 24, 2x WCH, 1x WCD 30, 1x WCB</p>
---	--	--

Aluminium perforated tool panels

	<p>ZLPG 4 Ref. No. 80712073 Dimensions (LxW): 1250 x 1000 mm Uncoated aluminium plate 1.2 mm</p>	<p>ZLPG 6 Ref. No. 80712097 Dimensions (LxW): 2000 x 1000 mm Uncoated aluminium plate 1.2 mm</p>
---	---	---

Edging strip for panels

	<p>ZLPKS Ref. No. 801010021 Edging strip, VPE 50 suitable for steel or aluminium sheet 1.0 – 1.5 mm</p>
---	--

All prices plus VAT and shipping. Our delivery and payment terms are applicable. See: www.sortimo.com/GTCT. Prices are only applicable for orders within Germany.



Sortimo original accessories

Safety equipment cleaning products and much more



Fuel canister 10 l

TSK10 Ref. No. 801008042

Fuel canister 10 l incl. spout (plastic)



Canister holders for 10 l

TSH10 Ref. No. 80779229

Canister holders for 10 l cans



Fuel canister 20 l

TSK20 Ref. No. 801009986

Fuel canister 20 l (steel) TÜV, GS tested

ET DTK Ref. No. 801015138

Replacement rubber seal



Canister holders for 20 l

TSH20 Ref. No. 80779236

Canister holders for 20 l cans



Spout for Canister

TSS Ref. No. 801009987

fits Sortimo 20 l canister



Auto fire extinguisher

ZF 2 Ref. No. 80713032

Auto fire extinguisher 2 kg

Powder extinguisher for fire classes A,B,C

High level of functional safety due to interior pressure cartridge.

Operates from -20° to +60°C



Auto fire extinguisher

ZF6 Ref. No. 80713070

Auto fire extinguisher 6 kg

Powder extinguisher for fire classes A,B,C

High level of functional safety due to interior pressure cartridge.

Operates from -20° to +60°C



Waste bin

ABE Ref. No. 80711144

Dim. (WxDxH): 190 x 180 x 300 mm

Waste bin incl. wall holder

AB Ref. No. 80711076

Bin bags, Pack of 50, strong and recyclable



Traffic cone lashing set

ZLKS1 Ref. No. 80711137

Traffic cone lashing set for 1-5 cones

Strap length = 1,63 m

Cones not included in the delivery.



Warning triangle

WADR Ref. No. 801009983

Warning triangle DIN 23641



High Visibility safety vests

WAVE Ref. No. 80720009

Safety vest in accordance with EN471 / DIN 30711



First Aid kit

VBK Ref. No. 80720023

First Aid kit DIN 13164



Water tap set, wide necked water canister, accessories

ZWA 5	Ref. No. 80779205	Water tap set 5 l incl. holder and draincock	Dim.: 295 x 165 x 295 mm
ZWA 10	Ref. No. 80779199	Water tap set 10 l incl. holder and draincock	Dim.: 295 x 165 x 405 mm
ZWHK5	Ref. No. 801009995	Wide necked water canister 5 l	Dim.: 290 x 160 x 290 mm
ZWHK10	Ref. No. 801009993	Wide necked water canister 10 l	Dim.: 290 x 160 x 290 mm
ZHWK	Ref. No. 801009992	Draincock for wide necked canister	
ZSPVC1	Ref. No. 80779212	PVC hose for the water tap set used to drain water out of the vehicle. 1 m	



Pump dispenser w. wall holder

ZHSK Ref. No. 80711007

Pump dispenser w. wall holder and 3 l of hand cream.

Cleans without water! biodegradable, protects the skin, effective cleansing of oil, fats, inks, tar printing ink etc.



Hand cleaning cream

ZHSK/ZHR Ref. No. 801010017

3 l hand cream Refill set

cleans without water! biodegradable, protects the skin, effective cleansing of oil, fats, inks, tar printing ink etc.



Paper towel dispenser

ZHA Ref. No. 80711106

Dimensions (LxW): 285 x 130 mm

ZPHS Ref. No. 80711113

Paper towel roll 260 x 125 mm

1 roll, 1 standard quality roll



Paper dispenser

ZRG Ref. No. 801012833

Paper dispenser (large) (paper not included)

Rolling off during driving is prevented by the self-clipping function. Fit for all standard paper rolls 320 mm wide and 400 mm max. paper roll diameter.



Tissue dispenser

ZREIT Ref. No. 80778949

Dimensions (LxW): 110 x 195 mm

Tissue dispenser (no holder)



Aerosol sprays for Sortimo in-vehicle equipment

ZLSPG3 Ref. No. 801005615

Aerosol spray FE3 for Globelyst (150ml) grey, RAL 240 7005

ZLSPB Ref. No. 80715197

Aerosol spray FE2+FE3 for Globelyst (150 ml) Royal blue, RAL 5010

All prices plus VAT and shipping. Our delivery and payment terms are applicable. See: www.sortimo.com/GTCT. Prices are only applicable for orders within Germany.

Sortimo original accessories



Bottle holder

FH 1,5 L
Ref. No. 801011367
 Bottle holder
 Mount to the side of a perforated panel



Aerosol spray holder

SDH 04-0 Ref. No. 801012774
 Dim. (WxDxH):: 311 x 33 x 18 mm

SDH 05-0 Ref. No. 801012775
 Dim. (WxDxH): 415 x 33 x 18 mm
 to be plugged on divider



Storage trays

AB 03-7 Ref. No. 801003699
 Dim. (WxDxH): 251 x 85 x 119 mm
 Weight: 0,6 kg



Document pocket

Keep your brochures, contracts, etc. in order and easily reachable with the Sortimo document pockets.

AB 03-17 Ref. No. 801003703
 Dim. (WxDxH): 241 x 75 x 327 mm
 Weight: 0,6 kg



AB 04-7 Ref. No. 801003700
 Dim. (WxDxH): 355 x 85 x 119 mm
 Weight: 0,7 kg



AB 04-12 Ref. No. 801003702
 Dim. (WxDxH): 345 x 75 x 253 mm
 Weight: 0,6 kg



AB 05-7 Ref. No. 801003701
 Dim. (WxDxH): 459 x 85 x 119 mm
 Weight: 0,9 kg



Vehicle safety lock

FSS Ref. No. 801012732
 Weight: 2,8 kg

Vehicle safety lock for most all van models. Security for valuables stored in your vehicle's storage area.



4 Load through hatch door

ZTDK Ref. No. 801009674
 Hatch opening (HxW): 233 x 248 mm

Dividing wall between load through hatch door and divider to load long cargo.



Ladder carry bag

ZTLT Ref. No. 80714886
 Weight: 0,54 kg

Carry bag for a telescopic ladder of up to 3.3 m. This easy to carry bag allows you to securely and neatly store your ladder.



Ladder safety foot

ZTLF Ref. No. 80714923
 Weight: 0,96 kg

1 pair of safety feet for the telescope ladder 3.3 m

Height adjustable – 225 mm max., suitable for stairs, non slip foot (you need 2) – for use on slippery or uneven surfaces.



Telescopic ladder 3.3 m

ZTL33 Ref. No. 80714909
 Dim. (WxDxH): 490 x 75 x 780 mm
 Weight: 10,40 kg

Length closed: 0.78 m, Length extended: 3.3 m
 Width: 0.49 m, Carrying capacity: 150 kg



Ladder bracket

ZTLH4 Ref. No. 80779281
 Weight: 0,50 kg

The ladder bracket is for the telescope ZTCL33. It can be easily mounted to the rear door of your vehicle for safe and quick use. Delivery does not include the ladder.

It is not compatible with the telescope combination ladder ZTCL23!



Telescopic combination ladder 2.3 m

ZTCL23 Ref. No. 801012159
 Dim. (WxDxH): 610 x 165 x 710 mm
 Weight: 14,00 kg

Max. working height: 3.7 m
 Weight: 14.0 kg, 8 rungs
 Length closed: 0.79 m, Length extended: 2.3 m
 Width: 0.48 m, Carrying capacity: 150 kg



5

Replacement parts for telescope ladder

ET TELE FÜ Ref. No. 801013820
 1 pair of replacement rubber shoes for the 3.3 m telescope ladder

ET TELE ZU Ref. No. 801013821
 1 pull ring for the telescope ladder

ET TELE AK Ref. No. 801013822
 1 protective cap fits both telescope ladders

ET TELECO FÜ Ref. No. 801013823
 1 pair of replacement rubber shoes for the 2.6m telescope ladder

ET TELECO GRUFU Ref. No. 801013824
 1 complete base for the telescopic combination ladder

All prices plus VAT and shipping. Our delivery and payment terms are applicable. See: www.sortimo.com/GTCT. Prices are only applicable for orders within Germany.



Sortimo original accessories

Lighting, power accessories



Mountable interior lamps

LASS 12/11 Ref. No. 80778970
Dimensions (WxDxH): 400 x 42 x 43 mm
Interior lamp 12 V, 11 Watt

LASS 24/11 Ref. No. 80777911
Dimensions (WxDxH): 400 x 42 x 43 mm
Interior lamp 24 V, 11 Watt
adjusts 270°, aluminium housing, easy installation, non-reflective

LR11 Ref. No. 80714930
Replacement tube 11 watt

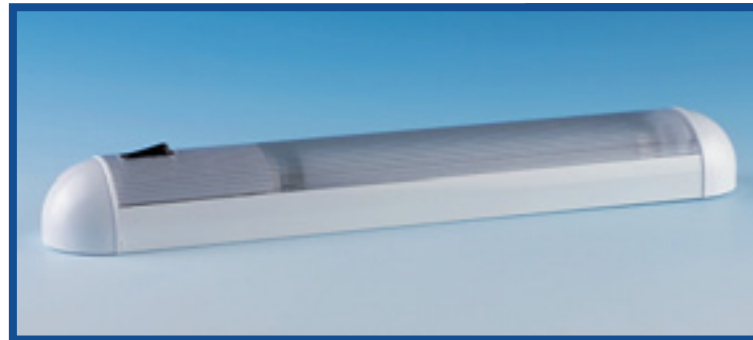

Mountable interior lamps

LAW6/12 Ref. No. 80750013
Dimensions (WxDxH): 380 x 62 x 41 mm
Interior lamp 12 V, 2x6 Watt

LR6 Ref. No. 49750211
Replacement tube 6 Watt



Mountable interior lamp

LAS16/12 Ref. No. 80750075
Dimensions (WxDxH): 360 x 55 x 50 mm
Interior lamp 12 V, 2x8 Watt

LR8 Ref. No. 49750204
Replacement tube 8 Watt



Mountable interior lamp

LA2/220 Ref. No. 80750099
Dimensions (WxDxH): 1280 x 120 x 110 mm
Interior lamp 220 V 36 Watt



Multiple socket outlet

ZSS 1 Ref. No. 801009971
Dimensions (WxDxH): 405 x 60 x 44 mm
220 V, 5 SCHUKO sockets
sturdy design, illuminated rocker switch



Safety multiple socket outlet

ZSS 2 Ref. No. 801009972
Dimensions (WxDxH): 475 x 90 x 30 mm
220 V, 4 SCHUKO sockets
sturdy design, Aluminum housing, circuit breaker to protect against overloads and short circuits. Residual current breaker for pers. protect. 16 A / 10 mA.



Safety multiple socket outlet

ZSS 3 Ref. No. 80713629
Dimensions (WxDxH): 475 x 80 x 30 mm
220 V, 5 SCHUKO sockets
device protection surge filter with failure indicator and replaceable fine-wire fuse. Aluminium housing



Surface mounted socket

ZSD12AB Ref. No. 801009981
Dimensions (WxDxH): 58 x 37 x 25 mm
12 V plug for internal use for the interior with 2 screw terminals

13,29 €



Plug for internal use

ZSD12AB2 Ref. No. 801005397
Dimensions (WxDxH): 75 x 50 x 35 mm
12 V plug for internal use
Vehicle cigarette lighter socket size



All prices plus VAT and shipping. Our delivery and payment terms are applicable.
See: www.sortimo.com/GTCT. Prices are only applicable for orders within Germany.

Sortimo original accessories

Lighting and power accessories



CEE feed-in socket outlet

ZCE 1 Ref. No. 80713643
 Dimensions (WxDxH): 105 x 105 x 15 mm
 vehicle exterior
 Dimensions (WxDxH): 78 x 92 x 80 mm
 vehicle interior
 For exterior use only 3 or 2 poles + PE,
 16 A, 220 V, seal towards vehicle exterior,
 security lid, splash proof according to IP X4,
 tensile control for coupling, Color: white



Adaptor lead for external plug

ZCES Ref. No. 80713667
 1,5 m with rubber fused plug for
 connection to an external plug, splash
 proof acc. to P X4, integrated SCHUKO
 socket 3 x 2.5 mm² SCHUKO rubber plug



Wave inverter

ZSW 300 Ref. No. 80714893
 Dimensions (WxDxH): 116 x 185 x 73 mm
 Wave inverter 12/250 V
 Tough Aluminium housing can be mounted
 virtually anywhere. Technical details: Input 12 V
 22 A, output 230 V pure sine wave 250 VA,
 spike (4 seconds) at 400 VA



Work lamp

Exterior lamp for mounting on vehicle for
 better lighting.
ZAS 12V Ref. No. 801013764
 Work lamp 12 V / 55 W
ZAS 24V Ref. No. 801013765
 Work lamp 24 V / 70 W



Professional hand held work lamp 12V

ZPHS12V Ref. No. 801013999
 Dim. (WxDxH): 105 mm x 245 mm x 120 mm
 Weight: 1,10 kg
 Safety hand held lamp according to IP 64;
 dustproof and protected against splash water,
 tough plastic housing, swivel lamp head, also
 deployable as emergency lamp according to VDE
 0108, maintenance free lead rechargeable bat-
 tery incl. Safety lamp charger, battery charging
 station, 220 V-power cable, 12 V-charging
 cable and attachment panel
 clear and orange.



On-off switch with control lamp

ZEASO Ref. No. 801014906
 On-off switch with control lamp

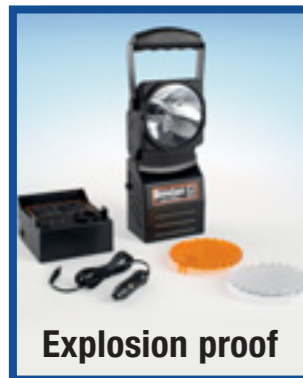

Professional hand held work lamp 12V

ZPHS12VEX Ref. No. 801013998
 Dim. (WxDxH): 105 mm x 245 mm x 120 mm
 Weight: 1,10 kg
 Safety hand held lamp according to IP 64;
 dustproof and protected against splash water,
 tough plastic housing, swivel lamp head, also
 deployable as emergency lamp according to VDE
 0108, maintenance free lead rechargeable bat-
 tery incl. Safety lamp charger, battery charging
 station, 220 V-power cable, 12 V-charging
 cable and attachment panel
 clear and orange.

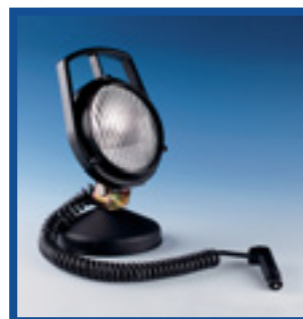

Hand held work lamps

ZHSW 12 Ref. No. 801009973
 12 V, 1,2 m cable
 55 watt, with plug for cigarette lighter socket,
 magnetic base, swivel bracket
 15° flood light
ZHSWV Ref. No. 801009974
 Extension reel 7 m
 12 V, for use with ZHSW,
 spiral

Spare parts for the professional hand held work lamp 12 V

- ET GBPH12V** Ref. No. 801014000
Replacement bulb
- ET AKKUPH12V** Ref. No. 801014001
Spare rechargeable battery



Rechargeable battery operated hand held torch

ZAHSW Ref. No. 80715104
 Rechargeable battery operated torch
 incl. charger tray
 2 brightness settings, Focus adjustment,
 flashing mode, 6 V / 4 AH battery, mains charger
 for 230/ 12 V, splash proof with lanyard.
 Sorry – no guarantee on
 the battery.
ET AKKU Ref. No. 801013529
 Spare rechargeable battery
 for ZAHSW



All prices plus VAT and shipping. Our delivery and payment terms are applicable.
 See: www.sortimo.com/GTCT. Prices are only applicable for orders within Germany.



simpleco® – simple and economical for all small vans.

- CITROËN
- DACIA
- FIAT
- FORD
- PEUGEOT
- RENAULT
- VOLKSWAGEN

Simple in-vehicle equipment that leaves you with much storage space

Sortimo International presents simpleco®, the new product line for small vans. The futuristically designed racks are fitted into the van in do-it-yourself style. Our simpleco® in-vehicle equipment ensures order in the vehicle while giving you considerable more room for bulky goods such as pallets.

You can order online

A new product – new ways of distribution for simpleco®. You'll find important information on the new simpleco® equipment in the Sortimo webshop. Using the Sortimo planning tools it is easy to find the perfect solution for the left and right side of your vehicle and order it online: www.simpleco-shop.de.

Low price thanks to the DIY style

You'll receive your order within three working days by parcel service. Fitting the equipment into your van is easy and you'll be ready for action in a very short time.



The simpleco® benefits:

- ▶ modern and fresh design for a professional image.
- ▶ extensive rack variations ensure order and safety.
- ▶ the Sortimo BOXXes fit perfectly into the simpleco® system.
- ▶ the loading room below the rack can be fully used.
- ▶ low net weight guarantees economy.
- ▶ convincing price/performance ratio.
- ▶ quick delivery within three working days.
- ▶ simple do-it-yourself installation.
- ▶ proven Sortimo quality.
- ▶ easy online ordering: www.simpleco-shop.de





We are never far away from you!

Your Sortimo contacts in Germany and around the world

The following pages will give you the addresses of our subsidiary companies and partners in Germany and around the world – in more than 28 countries.

Your Sortimo DIRECT team will gladly answer any question you may have.



Your Sortimo DIRECT team is ready for your question!

In Germany please call our free:

Tel. 0800 7678466

Fax 0800 7678499

Mail direct@sortimo.de

www.sortimo.de/direct

Sortimo in Germany

Branch offices and partners



Sortimo Headquarter
Dreilindenstraße 5
86441 Zusmarshausen
Tel. +49 8291 850-0
Fax +49 8291 850-250
E-Mail: info@sortimo.de
www.sortimo.de

Sortimo branch office Berlin
Gartenfelder Straße 29-37, Gebäude 44
13599 Berlin
Tel. +49 30 2005370-0
Fax +49 30 2005370-19
E-Mail: berlin@sortimo.de

Sortimo branch office Dresden
Hamburger Straße 14
01067 Dresden
Tel. +49 351 207362-0
Fax +49 351 207362-29
E-Mail: dresden@sortimo.de

Sortimo branch office Langenfeld
Lise-Meitner-Straße 19
40764 Langenfeld
Tel. +49 2173 10943-0
Fax +49 2173 10943-29
E-Mail: langenfeld@sortimo.de

Sortimo branch office Frankfurt/Main
Industriestraße 21
63150 Heusenstamm
Tel. +49 6104 64861-0
Fax +49 6104 64861-22
E-Mail: frankfurt@sortimo.de

Sortimo branch office Hamburg
Ausschläger Allee 178
20539 Hamburg
Tel. +49 40 571954-0
Fax +49 40 571954-54
E-Mail: hamburg@sortimo.de

Sortimo branch office München
Landshuter Straße 13
85716 Unterschleißheim
Tel. +49 89 37004560
Fax +49 89 37004589
E-Mail: muenchen@sortimo

Sortimo branch office Nürnberg
Benno-Strauß-Straße 37
90763 Fürth
Tel. +49 911 48035-35
Fax +49 911 48035-36
E-Mail: nuernberg@sortimo.de

Sortimo branch office Stuttgart
Nürtinger Straße 50
73257 Köngen
Tel. +49 7024 9726-0
Fax +49 7024 9726-10
E-Mail: stuttgart@sortimo.de

Sortimo branch office Zusmarshausen
Dreilindenstraße 5
86441 Zusmarshausen
Tel. +49 8291 850-149
Fax +49 8291 850-253
E-Mail: zusmarshausen@sortimo.de

Sortimo partner Bad Dübén
Rolf Frömmichen
Hauptstraße 10
04849 Authausen
Tel. +49 34243 26234
Fax +49 34243 22114
E-Mail:
sortimo-froemmichen@gmx.de

Sortimo partner Berlin
IFP GmbH
Buckower Chaussee 85
12277 Berlin
Tel. +49 30 72016005
Fax +49 30 89726753
E-Mail: ifp-berlin@t-online.de

Sortimo partner Bremen, Braunschweig & Celle
Wilfried Klatt GmbH
Im Finigen 15
28832 Achim
Tel. +49 4202 521730
Fax +49 4202 521732
E-Mail:
info@sortimo-station-bremen.de

Sortimo partner Brüggen
Bartsch + Feikes GmbH
Weiherfeld 18
41379 Brüggen
Tel. +49 2163 9997-0
Fax +49 2163 9997-77
E-Mail: info@bartsch-feikes.de

Sortimo partner Erfstadt
Thomas Schnabel
Behrensstraße 6
50374 Erfstadt
Tel. +49 2235 463535
Fax +49 2235 463536
E-Mail:
schnabel.ertstadt@t-online.de

Sortimo partner Erfurt
Gregor Werkzeuge
Inh. Mario Gregor
Otto-Schwade-Straße 6
99085 Erfurt
Tel. +49 361 6547424
Fax +49 361 6547426
E-Mail:
m.gregor@gregor-werkzeuge.de

Sortimo partner Essen
Heiko Dworak GmbH & Co.
Verwaltungs KG
Johanniskirchstraße 98
45329 Essen
Tel. +49 201 747008-1
Fax +49 201 747008-3
E-Mail:
hdworak@sortimo-essen.de

Sortimo partner Friesland-Oldenburg
Moritz Industrievertretungen -
Matthias Kruse
Färberstraße 2
26340 Zetel
Tel. +49 4453 4084
Fax +49 4453 6268
E-Mail:
sortimo-station-friesland@ewetel.net

Sortimo partner Fulda
Josef Leibold GmbH
Philipp-Reis-Straße 19-21
36093 Künzell
Tel. +49 661 31019
Fax +49 661 36697
E-Mail:
hojo@leibold-karosseriebau.de

Sortimo partner Gera
PFK Eickmeier GmbH & Co. KG
Wiesenring 8
07554 Korbußen
Tel. +49 36602 241-0
Fax +49 36602 241-23
E-Mail: pfk-eickmeier@t-online.de

Sortimo partner Gerstetten
Klaus Fries
Amselweg 5
89547 Gerstetten
Tel. +49 7323 3907
Fax +49 7323 921867
E-Mail:
sortimo-station-gerstetten@t-online.de

Sortimo partner Halle (Saale)
Gruber Fahrzeugbau GmbH
Pfännerhöhe 64
06110 Halle
Tel. +49 345 1202041
Fax +49 345 1202042
E-Mail: info@gruber-sortimo.de

Sortimo partner Hannover
HIG GmbH
Molkereistraße 33
30826 Garbsen
Tel. +49 5131 451288
Fax +49 5131 451914
E-Mail: vertrieb@hig-hannover.de

Sortimo partner Heilbronn
Klaus & Hartmut Stöckel GbR
Sägmühlstraße 45
74930 Ittlingen
Tel. +49 7266 911555
Fax +49 7266 911557
Mobil: 0173 3257383
E-Mail: stoeckel.fahrzeugbau@t-online.de

Sortimo partner Kaiserslautern
soflex GmbH
Mainzer Straße 114
67657 Kaiserslautern
Tel. +49 631 3507545
Fax +49 631 3507776
E-Mail: soflex-kl@t-online.de

Sortimo partner Kassel-Göttingen
Peter Welsch GmbH
Ellenbacher Straße 6
34123 Kassel
Tel. +49 561 524300
Fax +49 561 5296810
E-Mail:
info@sortimo-kassel.de

Sortimo partner Magdeburg
Lohanser GmbH
Schulzenstraße 18
39249 Barby
Tel. +49 39298 29262
Fax +49 39298 29261
E-Mail: info@lohanser.com

Sortimo partner Mannheim
soflex GmbH
Schildkrötstraße 29
68199 Mannheim
Tel. +49 621 84254-0
Fax +49 621 84254-29
E-Mail: contact@soflex-ma.de

Sortimo partner Marl
Gahlen Fahrzeugeinrichtungen
und Anhänger Vertriebs GmbH
Boschstraße 6
45770 Marl
Tel. +49 2365 81911
Fax +49 2365 508161
E-Mail: ggahlen@gmx.de

Sortimo partner Ostwestfalen-Lippe
THL GmbH
Stadttheider Straße 1-3
33609 Bielefeld
Tel. +49 521 30443-0
Fax +49 521 30443-22
E-Mail: info@thl-bielefeld.de

Sortimo partner Pforzheim
HS Fahrzeug- und
Betriebs-einrichtungen GmbH
Hohwiesenstraße 4
75217 Birkenfeld
Tel. +49 7231 911420
Fax +49 7231 358230
E-Mail:
hartmut-springmann@sspf.de

Sortimo partner Schweinfurt
Karl-Heinz Maar
Kreuzstraße 2
97532 Üchtelhausen
Tel. +49 9720 1882
Fax +49 9720 3923
E-Mail:
karl-heinz.maar@t-online.de

Sortimo partner Schwerin
HGS Fahrzeug- u.
Betriebs-einrichtungen GmbH
Lindenweg 1
19075 Pampow/Schwerin
Tel. +49 3865 829-0
Fax +49 3865 82922
E-Mail:
sortimo.schwerin@t-online.de

Sortimo partner Solingen
Manfred Becker
Kyllmannweg 29
42699 Solingen
Tel. +49 212 320002
Fax +49 212 320003
E-Mail:
becker@sortimo-solingen.de

Sortimo partner Teningen
SiTraFa GmbH & Co. KG
Siemensstraße 15
79331 Teningen-Nimburg
Tel. +49 7663 913080
Fax +49 7663 913089
E-Mail: bzoller@sitrafa.de

Sortimo partner Weser-Ems
C.A. Brill GmbH
Twentestraße 7
48527 Nordhorn
Tel. +49 5921 7800-13
Fax +49 5921 7800-10
E-Mail: jens.brill@ca-brill.de

Sortimo partner Wetzlar
Auto-Schach GmbH & Co. KG
Industriestraße 15-17
35582 Wetzlar-Dutenhofen
Tel. +49 641 97901-0
Fax +49 641 97901-10
E-Mail: n.held@auto-schach.de

You can also find your
on site contact person in
the internet by using our
comfortable postcode
search: www.sortimo.de

Sortimo International



Argentina

Sortimo
Adolfo E. Seifer
Francia 2545
1642 San Isidro
AR - Argentina
Tel. + 54 / 11 / 4723 8571
Fax + 54 / 11 / 4723 9112
seiferar@arnet.com.ar
www.sortimo.com

Austria

Sortimo GesmbH
Technologiezentrum Linz
Wiener Straße 131
Eingang A, 1.Stock
A - 4020 Linz
Tel. + 43 / 810 / 0810 45
Fax + 43 / 810 / 0810 46
office@sortimo.at
www.sortimo.at

Belgium

Sortimo BELUX bvba
Schaarbeeklei 207
B - 1800 Vilvoorde
Tel. + 32 / 2 / 3550 370
Fax + 32 / 2 / 3550 371
info@sortimo.be
www.sortimo.be

Czech Republic

FD servis Praha s.r.o.
Kůří 26
CZ - 251 01 Říčany u Prahy
Tel. + 420 / 323 / 6061 09
Fax + 420 / 323 / 6061 07
info@fdservispraha.cz
www.fdservispraha.cz

TOP CENTRUM

Jaroslav Novák
Rohovládova Bělá 91
CZ - 533 43 Rohovládova Bělá
Tel. + 420 / 466 / 9212 92
Fax + 420 / 466 / 9212 93
topcentrum@topcentrum.cz
www.topcentrum.cz

Denmark

Sortimo A/S
Greve Main 24
DK - 2670 Greve
Tel. + 45 / 43 / 5522 22
Fax + 45 / 43 / 5522 26
info@sortimo.dk
www.sortimo.dk

Finland

Suomen Autokaluste Oy
Ormuspellontie 9
FIN - 00700 Helsinki
Tel. + 358 / 207 558 816
panu.lahtinen@sortimo.fi
www.sortimo.fi

France

Sortimo S.A.R.L.
17 Rue Gay Lussac Z.I.
F - 95500 Gonesse
Tel. + 33 / 1 / 3987 44 66
Fax + 33 / 1 / 3987 51 68
info@sortimo.fr
www.sortimo.fr

Greece

Sortimo by Camper Hellas
8, Bizaniou
GR - 174 56 Alimos Athens
Tel. + 3 / 02 / 1098 2054 4
Fax + 3 / 02 / 1098 2652 1
info@camper.gr
www.camper.gr

Stathis

Transport Refrigeration
Dounas Theocharis & Co SA
Sindos Industrial Area, Entrance B
P.O. Box 11 34
GR - 570 22 SINDOS
Thessaloniki, Greece
Tel. + 30 / 23 / 1079 8300
Fax + 30 / 23 / 1079 8370
contact@stathis.com.gr
www.stathis.com.gr

Hungary

Hofmann Garázsipari Kft.
Budaörsi út 11.
H - 2092 Budakeszi
Tel. + 36 / 23 / 535 831
Fax + 36 / 23 / 535 849
ballun@t-online.hu
www.ballun.hu

Iceland

RAFVER HF
Skeifan 3 E-F
P.O. Box 84 33
IS - 128 Reykjavik
Tel. + 35 / 4 / 5812 333
Fax + 35 / 4 / 5680 215
rafver@rafver.is
www.sortimo.com

Israel

Sortline Ltd.
17 Zvi Bergman St.
Industrial Zone Sgula
P.O. Box 4622
IL - 49277 Petach-Tikva
Tel. + 97 / 23 / 9052 102
Fax + 97 / 23 / 9052 110
info@pba.co.il
www.sortline.co.il

Italy

Sortimo Italia S.r.l.
Via Crivellin, 7
I - 37010 Affi (VR)
Tel. 045 / 48 58 180
Fax 045 / 72 38 248
info@sortimo.it
www.sortimo.it
Numero Verde 800 855 717



Japan

MURATEC – KDS Corporation
No. 39, Matsuda-cho
Higashi-kujo, Minami-ku,
JP - 601-8036 Kyoto
Tel. + 81 / 75 / 6812 761
Fax + 81 / 75 / 6612 764
workman@muratec-kds.jp
www.sortimo.com

Korea

Rocky Co. Ltd
Tool Storage Systems
4BL/4LT Namdong Industrial Complex
618-3 Namchon Dong Nandong-Gu
Incheon 405-846 Korea
Tel. + 82 / 328 / 115500
Fax + 82 / 328 / 136670
rocky79@unitel.co.kr
www.rocky.co.kr

Lithuania

Skaida-nf uab
A. Gostauto 8 – 0224
LT - 01108 Vilnius
Tel. + 370 / 5 / 2613 443
Fax + 370 / 5 / 2613 443
skaida.nf@mail.lt
www.sortimo.com

Luxemburg

Sortimo Belux bvba
Schaarbeeklei 207
B - 1800 VILVOORDE
Tel. + 32 / 2 / 3550 370
Fax + 32 / 2 / 3550 371
info@sortimo.be
www.sortimo.be

Netherlands

Sortimo Nederland B.V.
Nijverheidstraat 11
NL - 2861 GX Bergambacht
Tel. + 31 / 182 / 35 60 60
Fax + 31 / 182 / 35 60 90
info@sortimo.nl
www.sortimo.nl

Norway

Sortimo A/S
Ulvenveien 92 A
N - 0581 Oslo
Tel. + 47 / 22 / 72 92 70
Fax + 47 / 22 / 72 92 72
firmapost@sortimo.no
www.sortimo.no

Poland

MOBILCAR S.C.
Dobrzeń 26
PL - 56-410 Dobroszyce
Tel. + 48 / 71 / 3153 532
Fax + 48 / 71 / 3153 519
sortimo@mobilcar.pl
www.mobilcar.pl

Dom Samochodowy
GERMAZ Sp.zo.o.
ul. Strzegomska 139
PL - 54-428 Wrocław
Tel. + 48 / 71 / 3582 071
Fax + 48 / 71 / 3577 524
afuksmiller@germaz.pl
www.germaz.pl

Russia

EQUINET
Borovaya Str. 7, bld. 2
RU - 111020 Moscow
Tel. + 7 / 95 / 780-6059
Fax + 7 / 95 / 780-6058
ershov@equinet.ru
www.sortimo.ru

Switzerland

Walter Rüegg AG
Sortimo Zentrum
Grabenackerstr. 1
CH - 8156 Oberhasli
Tel. + 41 / 44 / 8525 060
Fax + 41 / 44 / 8525 070
info@sortimo.ch
www.sortimo.ch

Slovakia

TECHNIA spol s.r.o.
Komárňanská cesta 72
940 01 Nové Zámky
Tel. + 421 / 35 / 6921 111
Fax + 421 / 35 / 6426 443
technia@technia.sk
www.technia.sk

Slovenia

Sorti d.o.o.
SORTIMO SLOVENIJA
Jamnikarjeva 14
SLO - 1000 Ljubljana
Tel. + 386 / 1 / 4231 880
Fax + 386 / 1 / 2565 200
sorti@sortimo.net
www.sortimo.net

Spain / Portugal

Sortimo Ibérica
Comercia-Servicios, S.L.
P.I. Garza 2,
Nave 29, Ctra M-106, km 2
ES - 28110 Algete (Madrid)
Tel. + 34 / 902 448899
Fax + 34 / 91 6289100
info@sortimo.es
www.sortimo.es

Sweden

Sortimo AB
Box 9173
400 94 Göteborg
Tlf.: 031 / 761 45 20
Fax: 031 / 776 99 50
E-Mail: info@sortimo.se
www.sortimo.se

UK & Ireland

Sortimo International Ltd
14 – 17 Ravenhurst Court
Risley
Warrington, Cheshire
WA3 6PN
FREEPHONE: 0800 027 5644
Phone + 44 / 1925 831636
Fax + 44 / 1722 320831
sales@sortimo.co.uk
www.sortimo.co.uk

USA

(Kanada, USA, Mexiko)
Sortimo North America, Inc.
2815 Colonnades Court,
Norcross, GA 30071
USA
Phone 877/812/6994 (toll free)
Phone + 1 / 404 812 6994
Fax + 1 / 404 812 9940
info@sortimo.us
www.sortimo.com

Venezuela

Servibus de Venezuela C.A.
Avenida Los Parceleros
Calle N° 17-92
Zona Industrial, Aguas Calientes
YU - Ureña – Estado Táchira
Tel. + 58 / 276 / 7874 865
Fax + 58 / 276 / 7870 279
servibus.ca@gmail.com
www.sortimo.com

Sortimo online world – Many ideas for professionals

As the market leader we also offer you many services, information and interactive offers around the topic of in-vehicle equipment on the internet.

www.sortimo.com

For all our products listed in our catalogue, you can find on our website:

- ▶ Additional information and
- ▶ Suggestions on equipping your vehicle

For more details please visit our download area.

www.sortimo.com/ newsletter

The newsletter regularly informs you about:

- ▶ current products
- ▶ trade shows and events
- ▶ worthwhile offers
- ▶ great prize draws

Order our free newsletter now!



Sortimo®

www.sortimo.com



Telephone

+49 8291 850-0



E-Mail

direct@sortimo.de



Fax

+49 8291 850-250



Internet

www.sortimo.com

Sortimo®

Sortimo International GmbH

Dreilindenstraße 5 · 86441 Zusmarshausen
DEUTSCHLAND

Tel. +49 8291 850-0 · Fax +49 8291 850-250

E-Mail info@sortimo.com · www.sortimo.com

Sortimo®
inside