



**DAUTEL**  
*LIFTER*

## **DL LIFTER**



- ✓ High-performance, load centre to 1000 mm
- ✓ Reliable and fail-safe
- ✓ Proven in practice
- ✓ For tough, continuous use
- ✓ Long-lasting and service friendly

The **DAUTEL LIFTER** brings cutting edge developments together with components proven 1000-fold to make for an unbeatable cost-benefit relationship.

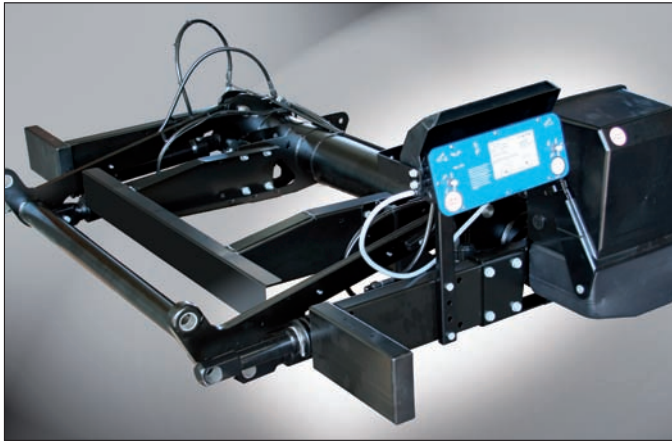

The **DAUTEL LIFTER** tail-gate lift generation fulfils the highest demands of European logistics professionals.

And this makes the transportation of heavy loads with the **DAUTEL LIFTER** especially easy for you: Double malfunction back-up provided by two separate, externally controlled, control circuits and the traversable, when under load, 2-point foot control; automatic hydraulic tilting of the platform; low-maintenance compound bearing bushings; reliable operation; low maintenance costs and reliable customer service – moreover the **1500 kg rated load with an unbeatable load centre\* of 1000 mm!**

The result is a tail-gate lift of the highest quality, designed for unbeatable safety, built for reliability during continuous use by our professional customers.

Select the right **DAUTEL LIFTER** from our product portfolio:

**DL 1000:**

rated load 1000 kg  
at a load centre\* of 700 mm,  
Net weight: approx. 355 kg

**DL 1500L:**

rated load 1500 kg  
at a load centre\* of 600 mm  
Net weight: approx. 385 kg

**DL 1500S:**

rated load 1500 kg  
at a load centre\* of 1000 mm  
Net weight: approx. 475 kg

**DL 2000L:**

rated load 2000 kg  
at a load centre\* of 750 mm  
Net weight: approx. 490 kg

**DL 2000S:**

rated load 2000 kg  
at a load centre\* of 1000 mm  
Net weight: approx. 535 kg

**DL 2500L:**

rated load 2500 kg  
at a load centre\* of 800 mm  
Net weight: approx. 540 kg

**DL 2500S:**

rated load 2500 kg  
at a load centre\* of 1200 mm  
Net weight: approx. 620 kg

**DL 3000S:**

rated load 3000 kg  
at a load centre\* of 1000 mm  
Net weight: approx. 620 kg

\* The load centre is measured from the beginning of and in the middle of the platform.

The weights provided are for aluminium platforms Height 1800 mm, Width 2520 mm.

## Simple and logical: the easy operation

## Reassuring: guaranteed all round safety

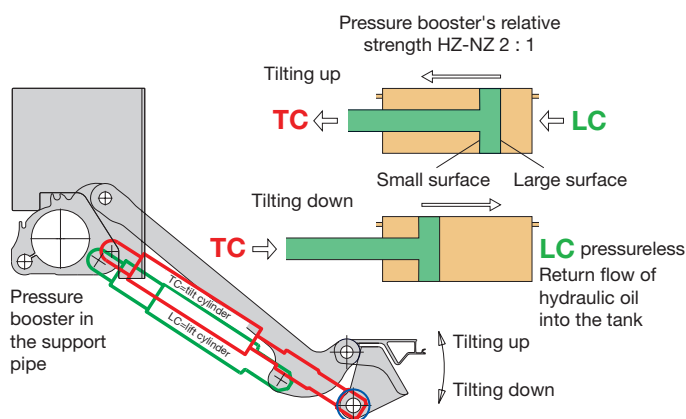

### The platform is tilted automatically

on the ground plus powerful resetting when lifting = double security by means of position-related release of the pressure transducer. This prevents uncontrolled tilting even for long platforms! Floor rollers are included as standard.

### Double safety control system

Late delivery because of a faulty tail-gate lift? Not with **DAUTEL**! High-quality components guarantee maximum reliability during operation. Even if the foot control should fail, separate electric circuits make it possible to continue working with the external control system. The electrical system is connected to a central terminal board with integrated switching logic - moisture-proof and low-maintenance due to vibration-proof connectors and numbered cables. A connection for automatic interior superstructure lighting is available, the -15 minute timer function (protected by pending design patent) protects against uncontrolled discharging of the vehicle battery.



### Easy to operate

The ergonomically-designed exterior control system is protected against dirt in a plastic box with self-closing cover and securely attached to the under-run guard. The waterproof toggle switches with spring contact are especially reliable – and easily operated even with gloves.



### 2-point foot control, traversable when under load

The unique control system, which has proven itself over more than 25 years, operates reliably with proximity switches unaffected by moisture.

### Simple and logical: – remote control

"Safetypoint" allows the open/close and lift/lower functions and the automatic tilting on the ground to be controlled precisely using a handheld transmitter while working in accordance with EC safety guidelines. The operator's stand is found on the platform.



## Unmatched: hoist gear and load centre

### Compact high-performance hoist gear, low net weight

each with two lift and tilt cylinders with double hard-chrome-plated piston rods, realised as a tubular support pipe with high ground clearance with a reinforced three-piece, warp-resistant under-run guard in accordance with EC 2006-20. The generous sizing of the lift arm makes it extremely warp resistant. Plastic bellows and protective tubes protect the piston rods and the hydraulic cylinder seals against damage. The platform opens hydraulically.

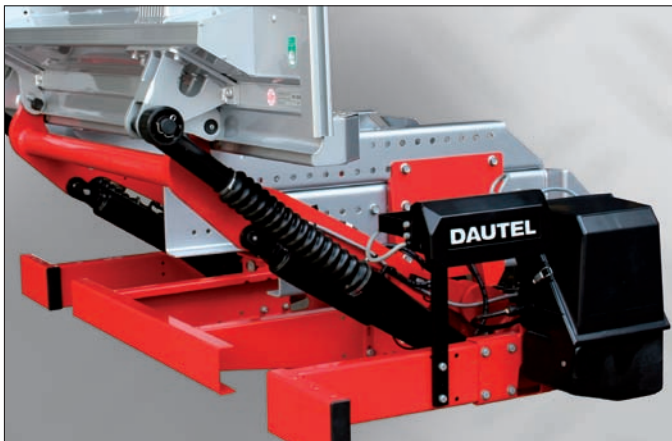

### Load centre up to 1000 mm!

The greatest flexibility in its class. Even more power when lifting and lowering, even greater freedom of movement when handling freight – this saves valuable time and makes larger and heavier loads possible.

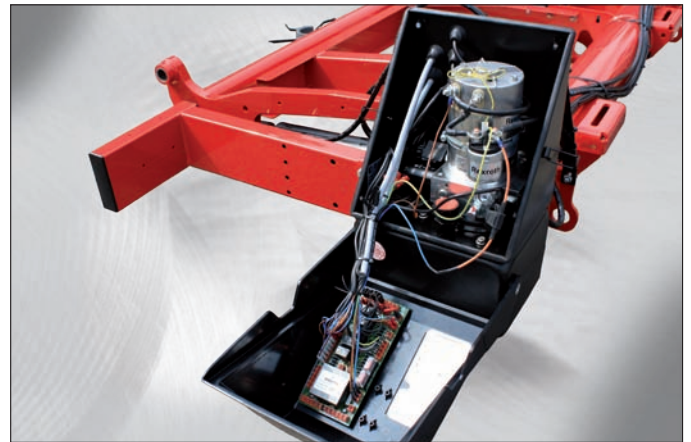

### Service-friendly drive

The quiet 24 volt drive aggregate with 2 kW motor and thermal overload switch, (DL 1000–DL 1500L also 12 volt, DL 2000S optional and DL 2500L– DL 3000S standard with powerful 3 kW motor), positioned in the direction of travel on the support pipe's right, is protected against moisture and stone chippings. All lines are easily accessible on the outside of the support pipe. Good heat transmission prevents the formation of damaging condensate. The hydraulic hoses, made from thermoplastic with stainless zinc-nickel fittings, are especially durable.

### Especially quiet operation

**DAUTEL LIFTERS** equipped as standard are also very quiet. An optional closing damper for the platform is available for night delivery. The platform can be clad with a noise-dampening covering.

### Safety assured by DAUTEL's competence

We check the mounting options for every **DAUTEL LIFTER** and coordinate these with the installers. Delivery is customised precisely, and a function test in the factory is a matter of course.



## Long service life: Top quality from A to Z

## Important: Low maintenance and service-friendly

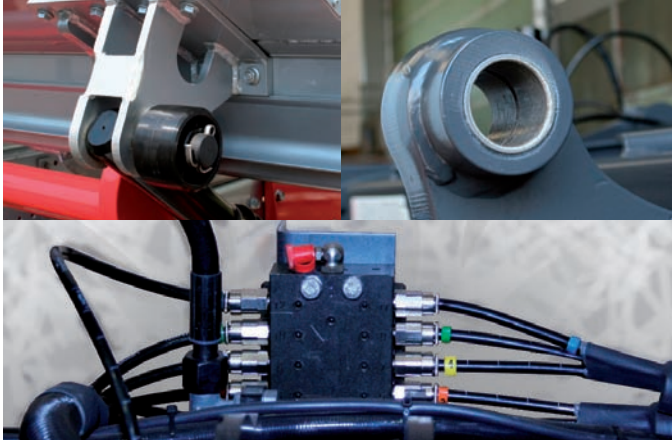

The hoist gear (support pipe, linkage, under-run guard, suspension plates) for the DL 1500S– DL 2000S are optionally available in a hot-dip galvanised model.

### Cost-effective upkeep

When operating a tail-gate lift, not only low acquisition costs count but also cost effective upkeep. High performance material, high-quality workmanship and clever details ensure low upkeep costs with **DAUTEL** for the entire service life.

### Low-maintenance compound bearing bushings

Large-scale bearing surfaces,  $\varnothing 35$  mm, made of QPQ-coated steel bolts and compound bearing bushings make environmentally friendly, self-lubricating dry running possible, due to the solid lubricants in the material, and are designed for tough, continuous operation. On request, your **DAUTEL LIFTER** can also be equipped with greaseable bolts featuring a single nipple, central lubrication system.

### Especially low-maintenance

The bearings' lateral thrust faces and the bolt overhangs should be lubricated occasionally with a spray lubricant or with a few drops of lubricating oil. This protects against corrosion and increases the service life. Maintenance must be carried out once a year.

### Optimum protection against corrosion

Steel components are pre-treated and painted with a thick layer of KTL as standard, similar to RAL 9005 black, which provides 1000 hours of resistance in salt spray tests. For users with higher requirements, **DAUTEL** offers optional additional, high-performance painting in a RAL colour as required by the HGV manufacturer.

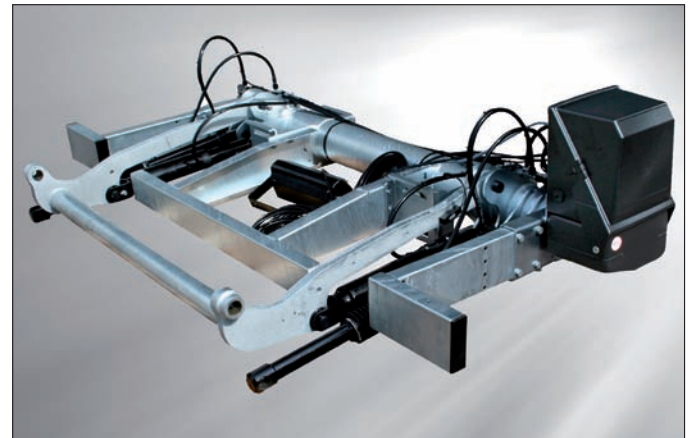

### Simple, quick assembly

Short, optimally-shaped support arms and steep installation angles make installation possible in very limited space. The fastening plates are screwed to the support pipe and can be adjusted transversely. The three-piece under-run guard can be adjusted longitudinally. A VEHH code A interface for the control current is included. Optionally, the main current and earth cable can be equipped with a VEHH code B interface.

## Platform systems

Your tail-gate lift platform is your driver's second workplace. Careful selection is decisive for your HGV's ergonomics.



### Hot-dip galvanised steel platform for extreme applications

hot-dip galvanised inside and outside, therefore highest possible protection against corrosion (patent pending). Available for the **DAUTEL LIFTERS** from DL 1500S, platform height 1800–2400 mm. Optional Fixorand profile and screw fastened aluminium sign panel are available. The anti-slip feature is classified as permanent in accordance with DIN 51130, R11 in all directions.



### Type N aluminium platform durable and economic

Flat design with two screw-fastened, black KTL painted, steel substructures with integrated connecting heads, fluted wear surface at the tips, transversely-installed cold-joined 40 mm profiles. Classification of the anti-slip characteristic in accordance with DIN 51130, R11 in downtilt direction. DL 1000–2000S, depending on the rated load height 1600–2400 mm.



### Conical type C aluminium platform ideal for your advertising signage

Durable design with longitudinally-fluted standing profiles, platform tip with fluted wear surface as a transversely installed profile with transverse fluting, steel connecting head, KTL painted black. Classification of the anti-slip property in accordance with DIN 51130, R10 with transverse milling in downtilt direction. DL 750–2000S, depending on the rated load height 1450–2400 mm.



### Type P aluminium platform for very tough applications

Flat design with two welded aluminium substructures and one cross-member, fluted wear surface at tips and substructures; transversely-installed 40 mm profiles with transverse fluting, welded on both sides. Classification of the anti-slip property in accordance with DIN 51130, R10, with R11 noise-dampening coating in downtilt direction. Unbeatable warp and roll-over resistance. Lateral edging profile with longitudinal fluting for greater security. DL 1500S–2000S, depending on the rated load height 1805–2705 mm.



## Drop-down protector systems

The fail-safe drop-down protector is a crucial quality feature in your logistics chain. Select the model and the location carefully.

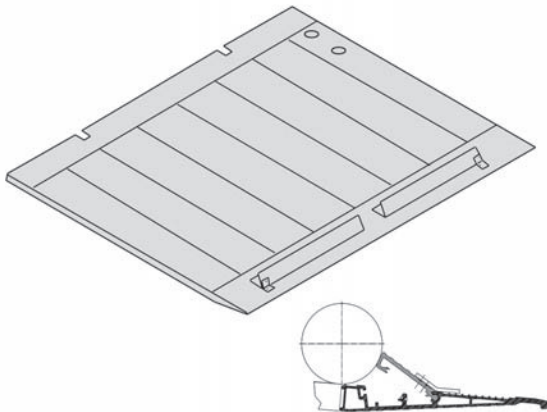

### Type V1, in type C aluminium platform, P

- Durable design for 2 roller containers, width for type C platform 700/900 mm, type P 800 mm
- Can be installed and secured individually
- Wheel  $\varnothing$  max. 120 mm
- Installed approx. 370 mm in front of the tip for type C platform, approx. 356 mm for type P platform

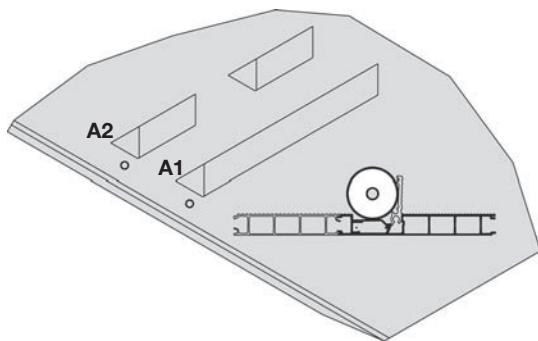

### Type A2, in type N Aluminium platform

- Universal drop-down protector comprising 2 flaps, each 210 mm wide, for 1 or 2 roller containers
- Exterior width 720 mm
- Wheel  $\varnothing$  max. 200 mm
- Positioned approx. 1010 mm from the beginning of the platform or approx 190 mm in front of the platform tip

### Type A1, in type C and P aluminium platform

- For tough applications due to no cut-outs being required in the platform
- For 2 roller containers
- Width 700 mm for type C platform, 800 mm for type P
- Wheel  $\varnothing$  max. 200 mm
- Position for type C platform approx 310 mm in front of the platform tip
- For type P platform, positioned approx. 1130 mm from the beginning of the platform or approx. 314 mm in front of the platform tip

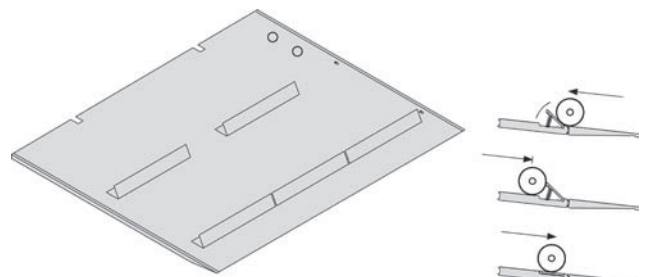

### Type F 1 in type C, N and P aluminium platform

- For tough applications due to no cut-outs being required in the platform
- For 2, 3, 4 or 5 roller containers
- Width approx. 700 mm for type C platform, approx. 740 mm for type N, 800 mm for type P
- Position for type C platform approx 370 mm in front of the platform tip
- For type N platform, positioned approx. 950 mm from the beginning of the platform or approx. 256 mm in front of the platform tip
- For type P platform, positioned approx. 1070 mm from the beginning of the platform or approx. 356 mm in front of the platform tip
- Wheel  $\varnothing$  max. 120 mm
- Up to 3 drop-down protectors installed continuously with sliding latches
- Can be locked individually, traversing function from the platform tip

### Type F 1 in hot-dip galvanised steel platform for 2 roller containers

- Width approx. 1000 mm
- Positioned approx. 430 mm in front of the tip
- Wheel  $\varnothing$  max. 120 mm

## The DAUTEL complete programme Quality from the start

**DAUTEL** offers you many industry-specific solutions: From the design for transporters with a rated load from 500 kg to 3000 kg at a load centre of 1000 mm to special solutions for trailers, semitrailers and HGVs with combined low and normal coupling and under-run designs, **DAUTEL SLIDER DS -VA/ VB/VT XXL**. The electronically-controlled charge cable with charge current monitor for the auxiliary battery system for semitrailers/trailers ensures reliable operation.

Our business is DIN EN 9001:2000 certified.



## Europe-wide customer service

**DAUTEL** has been active throughout Europe for many years – its own branches in Switzerland, the Netherlands, Italy, Austria and its sales partners in Great Britain, Ireland, Poland, the Czech Republic and Hungary form a sales and service network available to you throughout Europe.



The **DAUTEL** load safety equipment, with and without locks, for payloads up to 27 t, in accordance with DIN EN 12195/VDI 2700, is DEKRA certified.



Technical data subject to change, illustrations non-binding. 09/2010



DAUTEL GmbH  
Dieselstrasse 33 · 74211 Leingarten · Germany  
Tel. +49 7131 407-0 · Fax +49 7131 407-107  
E-Mail info@dautel.de · Internet www.dautel.de